

Research Report 1408

The Hewlett-Packard HP-41CV Hand-Held Computer  
as a Medium for Teaching Mathematics  
to Fire Control Systems Repairers

AD-A160 440

John A. Boldovici and Thomas D. Scott

Training and Simulation Technical Area  
Training Research Laboratory



U. S. Army

Research Institute for the Behavioral and Social Sciences

October 1984

Approved for public release; distribution unlimited.

U. S. ARMY RESEARCH INSTITUTE  
FOR THE BEHAVIORAL AND SOCIAL SCIENCES

A Field Operating Agency under the Jurisdiction of the  
Deputy Chief of Staff for Personnel

EDGAR M. JOHNSON  
Technical Director

L. NEALE COSBY  
Colonel, IN  
Commander

---

Technical review by

Angelo Mirabella  
Steven Sabat

NOTICES

DISTRIBUTION: Primary distribution of this report has been made by ARI. Please address correspondence concerning distribution of reports to: U.S. Army Research Institute for the Behavioral and Social Sciences, ATTN: PERI-TST, 5001 Eisenhower Avenue, Alexandria, Virginia 22333.

FINAL DISPOSITION: This report may be destroyed when it is no longer needed. Please do not return it to the U.S. Army Research Institute for the Behavioral and Social Sciences.

NOTE: The findings in this report are not to be construed as an official Department of the Army position, unless so designated by other authorized documents.

REPORT DOCUMENTATION PAGE		READ INSTRUCTIONS BEFORE COMPLETING FORM
1. REPORT NUMBER ARI Research Report 1408	2. GOVT ACCESSION NO. AD-A160440	3. RECIPIENT'S CATALOG NUMBER
4. TITLE (and Subtitle) THE HEWLETT-PACKARD HP-41CV HAND-HELD COMPUTER AS A MEDIUM FOR TEACHING MATHEMATICS TO FIRE CONTROL SYSTEMS REPAIRERS	5. TYPE OF REPORT & PERIOD COVERED Final Report January 1984-June 1984	
	6. PERFORMING ORG. REPORT NUMBER --	
7. AUTHOR(s) John A. Boldovici Thomas D. Scott	8. CONTRACT OR GRANT NUMBER(s) --	
	9. PERFORMING ORGANIZATION NAME AND ADDRESS U.S. Army Research Institute for the Behavioral and Social Sciences (PERI-II) 5001 Eisenhower Avenue, Alexandria, VA 22333-5600	
11. CONTROLLING OFFICE NAME AND ADDRESS U.S. Army Research Institute for the Behavioral and Social Sciences 5001 Eisenhower Avenue, Alexandria, VA 22333-5600	10. PROGRAM ELEMENT, PROJECT, TASK AREA & WORK UNIT NUMBERS 2Q162717A70	
	12. REPORT DATE October 1984	
14. MONITORING AGENCY NAME & ADDRESS (if different from Controlling Office) --	13. NUMBER OF PAGES 70	
	15. SECURITY CLASS. (of this report) Unclassified	
15a. DECLASSIFICATION/DOWNGRADING SCHEDULE --		
16. DISTRIBUTION STATEMENT (of this Report)  Approved for public release; distribution unlimited		
17. DISTRIBUTION STATEMENT (of the abstract entered in Block 20, if different from Report)  --		
18. SUPPLEMENTARY NOTES Work performed by ARI Training Research Laboratory, H. F. O'Neil, Jr., Director, in fulfillment of a Memorandum of Understanding with the U.S. Army Communications Technology Office, the U.S. Army Ordnance Center and School, and the Army Training Center, Fort Dix, NJ.		
19. KEY WORDS (Continue on reverse side if necessary and identify by block number) Hand-held computers Fire-control systems repairers Evaluation design Training effectiveness		
20. ABSTRACT (Continue on reverse side if necessary and identify by block number) A comparison was conducted between the performance of two groups of 30 fire control systems repairers after completing the mathematics part of the 45G10 course. The evaluation was designed by one of the cooperating military agencies, and the authors analyzed the resulting data. One group of repair personnel used the Hewlett-Packard HP-41CV hand-held computer in training. The other group received conventional training, without computers. The difference between the two groups' performance on an end-of-training mastery test was not statistically significant. (Continued)		

ARI Research Report 1408

20. (Continued)

Flaws in the evaluation design prevented determining whether the findings of no difference between the groups' performance was due to the kinds of training (computer and conventional) or to:

1. Differences between entry-level mastery of course material by the two groups.
2. Different amounts of training by the two groups.
3. An end-of-course test which was not difficult enough to reveal proficiency differences between the two groups.

Several recommendations were made for designing and conducting future evaluations. The main recommendations were that:

1. Test scores for untrained persons be obtained, against which the scores of trained people can be compared.
2. Records be kept of the amounts of practice by each member of the compared groups.
3. End-of-course tests be difficult enough to reveal differences between good and mediocre performances.

An experimental design was presented for future use which uses a no-training control group, separates the effects of amount and kind of training, and is likely to detect proficiency differences.

**Research Report 1408**

**The Hewlett-Packard HP-41CV Hand-Held Computer  
as a Medium for Teaching Mathematics  
to Fire Control Systems Repairers**

**John A. Boldovici and Thomas D. Scott**

Training and Simulation Technical Area  
Robert J. Seidel, Chief

**Training Research Laboratory**  
**Harold F. O'Neil, Jr., Director**

U.S. ARMY RESEARCH INSTITUTE FOR THE BEHAVIORAL AND SOCIAL SCIENCES  
5001 Eisenhower Avenue, Alexandria, Virginia 22333-5600

Office, Deputy Chief of Staff for Personnel  
Department of the Army

October 1984

---

Army Project Number  
2Q162717A790

Human Performance Effectiveness  
and Simulation

*Approved for public release; distribution unlimited*

**ARI Research Reports and Technical Reports are intended for sponsors of R&D tasks and for other research and military agencies. Any findings ready for implementation at the time of publication are presented in the last part of the Brief. Upon completion of a major phase of the task, formal recommendations for official action normally are conveyed to appropriate military agencies by briefing or Disposition Form.**

---

## FOREWORD

---

Providing Technical Advisory Service to many Army Organizations is an important part of the Army Research Institute mission. This report is the result of an agreement between ARI, the Army Communications Technology Office, Training Development Institute, Ordnance Center and School, and the Army Training Center at Fort Dix, New Jersey. ARI was responsible for analyzing and reporting the results of an evaluation designed and implemented by the other organizations.

No differences were found between end-of-course test scores of soldiers who used a hand-held computer in training, and soldiers who received conventional training without computers. Flaws in the evaluation design, however, prevented determining whether there was truly no advantage to using the computer, or that the results were due to other factors. The authors therefore make specific recommendations for the design of future, related evaluations.



EDGAR M. JOHNSON  
Technical Director





## EXECUTIVE SUMMARY

---

The TRADOC Training Development Institute (TDI) and the New Technology Office of the US Army Ordnance Center and School (USAOC&S) began work in 1981 to survey hand-held computers (HHCs), and to identify potential applications for their use in training. The survey (Francis and Levy, 1982) described a number of devices and courses in which HHCs seemed potentially useful as training media. One of the HHCs and one of the courses described in the survey were used in the present investigation.

## REQUIREMENT

The requirement for this research resulted from a Memorandum of Understanding in which the responsibilities were divided as follows:

1. US Army Communications Technology Office (ACTO): coordination.
2. US Army Training Development Institute: contract for test and evaluation plan.
3. US Army Ordnance Center and School: implement test and evaluation plan.
4. Army Training Center (ATC), Fort Dix, New Jersey: implement subsequent test and evaluation of Quasar Panasonic HHC.
5. US Army Research Institute (ARI): analyze data and write reports.

The purpose of the research was to estimate the effectiveness, efficiency, user acceptance, implementation quality, reliability, and cost of the Hewlett-Packard HP-41CV, as used for training Fire Control Systems Repairers (MOS 45G10).

## PROCEDURE

Sixty soldiers in the 45G10 course were divided into two groups of 30 each. One group used the Hewlett-Packard HP-41CV hand-held computer during training for the mathematics part of the course. The other group received conventional training for the mathematics part of the course,

without using computers. An end-of-training mastery test was administered to members of both groups, and a questionnaire was administered to members of the HHC group and the instructor.

## **FINDINGS**

The questionnaire responses indicated that the HP-41CV was acceptable to the students and instructor who used it for learning and teaching mathematics.

The difference between the two groups' performance on the end-of-training mastery test was not statistically significant. Flaws in the evaluation design, however, prevented determining whether the finding of no difference between the groups' performance was due to the kinds of training (computer vs. conventional) or to:

1. Differences between entry-level mastery of course material by the two groups.
2. Different amounts of training by the two groups.
3. An end-of-course test which was not difficult enough to reveal proficiency differences between the two groups.

## **USE OF FINDINGS**

Several recommendations were made for designing and conducting future evaluations. The main recommendations were that:

1. Test scores for untrained persons be obtained, against which the scores of trained people can be compared.
2. Records be kept of the amount of practice by each member of the compared groups.
3. End-of-course tests be difficult enough to reveal differences between good and mediocre performances.

An experimental design was presented for future use which uses a no-training control group, separates the effects of amount and kind of training, and is likely to detect proficiency differences.

THE HEWLETT-PACKARD HP-41CV HAND-HELD COMPUTER AS A MEDIUM FOR  
TEACHING MATHEMATICS TO FIRE CONTROL SYSTEMS REPAIRERS

CONTENTS

---

	Page
INTRODUCTION . . . . .	1
Purpose . . . . .	1
HP-41CV . . . . .	1
Course Content . . . . .	2
METHOD . . . . .	2
Subjects . . . . .	2
Equipment . . . . .	2
Procedure . . . . .	2
RESULTS AND DISCUSSION . . . . .	3
Effectiveness . . . . .	3
Efficiency . . . . .	5
User Acceptance . . . . .	6
Quality of Implementation . . . . .	10
Reliability . . . . .	11
Cost . . . . .	11
SUMMARY . . . . .	12
RECOMMENDATIONS . . . . .	14
REFERENCES . . . . .	17
APPENDIX A. INSTRUCTOR MANUAL FOR HP-41 COMPUTER LESSON . . . . .	A-1
B. EXCERPTS FROM THE PROGRAM OF INSTRUCTION, "COURSE 113: 45G10, FIRE CONTROL SYSTEMS REPAIRER" (INCLUDES POI FOR ANNEX C, "BASIC DIGITAL CIRCUITS") . . . . .	B-1
C. END-OF-ANNEX C TESTS AND ANSWERS . . . . .	C-1
D. STUDENT QUESTIONNAIRE . . . . .	D-1
E. INSTRUCTOR QUESTIONNAIRE . . . . .	E-1
F. HP-41C/CV SPECIFICATIONS . . . . .	F-1

CONTENTS (Continued)

---

Page

LIST OF TABLES

Table 1. Percents of students (n = 30) responding in each rating category for questionnaire items 5 through 11 (1 = highest, 5 = lowest) . . . . . 8

2. Percents of students (n = 30) responding in various categories to the question, "What did you like about using the computer in this annex?" . . . . . 9

LIST OF FIGURES

Figure 1. Mean time (in minutes) reported to have been spent by the HHC students (n = 30) on each kind of practice problem . . . . . 6

2. HHC group's ratings of the usefulness of the 11 kinds of practice exercises . . . . . 10

## THE HEWLETT-PACKARD HP-41CV HAND-HELD COMPUTER AS A MEDIUM FOR TEACHING MATHEMATICS TO FIRE CONTROL SYSTEMS REPAIRERS (45G10)<sup>1</sup>

---

Very Large Scale Integration microcircuits have allowed reducing the size of microcomputers, with attendant increases in portability, and extension to applications outside offices and classrooms.

The TRADOC Training Development Institute (TDI) and the New Technology Office of the US Army Ordnance Center and School (USAOC&S) began work in 1981 with Battelle Columbus Laboratories to survey hand-held computers (HHCs), and to identify potential applications for their use in training. The survey (Francis and Levy, 1982) described a number of devices and courses in which HHCs seemed potentially useful as training media. One of the HHCs and one of the courses described in the Francis and Levy (1982) survey were used in the present investigation.

### Purpose

The purpose of this research was to estimate the effectiveness, efficiency, user acceptance, implementation quality, reliability, and cost of the Hewlett-Packard HP-41CV, as used for training Fire Control Systems Repairers (MOS 45G10).

### HP-41CV

Francis and Levy (1982) described the Hewlett-Packard HP-41CV as,

...a device that looks like a calculator, [with] a comparatively large memory and numerous peripherals....there is a selection of programmed application ROMs, a user's library, and a newsletter. Though marketed as a calculator, internally this device resembles a computer more than does [for example] the Sharp [PC1211]/Radio Shack [TRS-80PC]...(p.4).

---

<sup>1</sup>The findings reported here are not official Department of the Army position unless so designated by authorized documents. The test and evaluation plan for this research was provided by Battelle Columbus Laboratories under contract to the US Army Training Development Institute. The data were analyzed, and the report was written by John A. Boldovici and Thomas Scott of the US Army Research Institute (ARI), in fulfillment of a Memorandum of Understanding with US Army Communications Technology Office (ACTO), the US Army Ordnance Center and School (USAOC&S), and the Army Training Center (ATC), Fort Dix, New Jersey.

Specifications for the device, presented as Appendix F in Francis and Levy's (1982) report, are reproduced as Appendix F in this report.

### Course Content

The 45G10 MOS course was designed to teach enlisted personnel to perform direct and general support maintenance of computer, ballistic, laser rangefinders and designators; tank-mounted thermal sights; and related test equipment at skill level one. The subject matter includes general electricity and electronics; basic digital circuits; precision soldering; direct and general support (DS/GS) maintenance of ballistic computers, laser rangefinders, and designators; tank-mounted thermal sights, and TMDE. The course also covers common maintenance subjects: publications, tools, maintenance forms, safety, maintenance discipline, and soldier's manual orientation.

Mastering the electronics and digital circuits parts of the course requires mathematical skills which will be described later. The practice exercises for developing these mathematical skills were implemented on the HP-41CV, and with conventional paper-and-pencil materials.

### **METHOD**

#### Subjects

The subjects were 60 soldiers enrolled in the 45G10 training course, who were divided nonsystematically (but not randomly) into two groups of 30 each.

#### Equipment

An HP-41CV was given to each member of one group, which was designated "HHC." Subjects in the other (CONV) group used conventional paper-and-pencil practice. No other special equipment was used for either the HHC or CONV group.

The course instructor was given an HP-41CV and a printer, which was used to print out a use record for each HP-41CV assigned to the HHC students. The print-out information included the number of drill problems given, the number of drill problems incorrect, the number of problems not attempted, and the highest level of difficulty achieved.

#### Procedure

Instructors were given an introduction to the HHC, and information on its care, use, and capabilities before the course began. (See outline in Appendix A.) Students in the 45G course were given similar training. Students' use of the HHC was self-paced, with timing and amount of use at the students' discretion.

The Outline Program of Instruction for the Fire Control System Repairer course is excerpted in Appendix B. The HHC was employed in support of Annex C of the course, which is allocated 48 hours, or approximately 6 percent, of the total 795 hours of instruction. Annex C mathematics was chosen for implementation of the HHC for two reasons: instructional time was short, and the topics to be covered seemed suited to HHC applications.

Programmers at the Battelle Columbus Laboratories wrote, pilot tested, and refined the HP-41CV software. The practice exercises addressed:

1. Decimal to binary conversion.
2. Binary to decimal conversion.
3. Decimal to octal conversion.
4. Octal to decimal conversion..
5. Decimal to hexadecimal conversion.
6. Hexadecimal to decimal conversion.
7. One digit hexadecimal (hangman game).
8. Two digit hexadecimal (hangman game).
9. Binary addition.
10. Binary subtraction.
11. Boolean logic.

Two equivalent<sup>2</sup> forms of an end-of-annex test were constructed. Copies of the forms were shuffled, and one copy was given to each student in the two groups on completion of Annex C. The test forms are presented with answer keys in Appendix C. Students in the HHC group were then asked to complete a questionnaire, which is shown in Appendix D.

## RESULTS AND DISCUSSION

### Effectiveness

The mean scores for the end-of-annex test were 92.5 percent for HHC group, and 87.0 percent for the CONV group. The difference is not statistically significant. This does not mean that no differences existed between the effectiveness of HHC and CONV training. It means, rather, that any differences which may have existed were not sufficiently reliable to be detected by the procedures and tests used in this evaluation.

Factors other than training frequently affect students' scores on end-of-course achievement tests. These factors include:

---

<sup>2</sup>A Mann-Whitney U test revealed no statistically significant difference between mean numbers of errors on the two forms.

1. Students' entry-level ability.
2. Students' entry-level mastery of course material.
3. Amount of training.
4. Test difficulty.

Students' entry-level ability. Students were, as noted earlier, assigned nonsystematically to the HHC and CONV groups. Doing so provided a hedge against differences between the groups' entry-level abilities, but did not guarantee that such differences were absent.

Two sets of Armed Services Vocational Abilities Battery (ASVAB) scores were examined for clues about possible differences between the HHC and CONV groups' entry-level abilities. Mean General Technical (GT) scores, which estimate verbal and mathematical abilities, were 114.6 for the HHC group, and 114.1 for the CONV group. The difference is not statistically significant. Mean Electronics (EL) scores were 115.5 for the HHC group, and 116.3 for the CONV group. The difference also is not statistically significant. To the extent that the GT and EL scores reflect students' ability to learn the material presented in Annex C, therefore, that ability had no differential effect on the groups' Annex C test scores.

Students' entry-level mastery of course material. No data were available for examining possible differences between the groups' pre-training mastery of the Annex C material. Estimating how much of the material students had mastered before Annex C training began would have required comparing the HHC and CONV groups' end-of-annex scores to either: (a) end-of-annex scores achieved by a no-training control group, or (b) HHC and CONV pre-test scores. The unavailability of either of these measures was unfortunate. Their absence precluded comparing the two groups' pre-training proficiency. Their absence also precluded ascribing any causal relation between training on the one hand, and Annex C test scores on the other. As is often the case in device evaluations, the equivalence of the alternative programs was examined without regard for questions of whether and how much either program was better than no training at all.

Amount of Training. Of the many factors which affect training effectiveness, one of the most potent is amount of training. Given relevance (that is, not teaching "the wrong things"), amount of training usually exerts stronger effects than media do. (See, for example, Rose, Wheaton, Leonard, Fingerman, and Boycan; 1976.) Objective data on the amounts of training received by the HHC and CONV groups were, unfortunately, not obtained in this evaluation.<sup>3</sup> The finding of no difference between the HHC and CONV groups' end-of-annex scores may

---

<sup>3</sup>Self reports about the amount of training received by the HHC group were gotten and will be discussed later. These data are, however, irrelevant to the present discussion.



therefore be due to differences between the amounts of training received by the two groups. If one group did in fact practice more than the other did, then the finding of no difference between the end-of-annex test scores simply suggests that, given two media or programs of unequal effectiveness, more practice with the less effective medium can yield proficiency levels which are comparable to those achieved with less practice using the more effective medium.

Test difficulty. Test difficulty is defined as the difference between the maximum possible score and the observed score(s). As observed scores approach the maximum possible score, a test becomes, by definition, easier. When compared groups score at or near 100 percent on a test, "ceiling effects" are said to occur. Ceiling effects can happen because training was extremely effective, because students had mastered much of the material covered by the test before training began, or for any reason that made performance on the test easy for the test takers. Such results may be desirable in training, but are not desirable in evaluations of training effectiveness. The reason for this is that measuring differences between groups' performance requires variance between the groups' test scores. Little variance occurred between the compared groups' test scores in this evaluation, and statistically significant differences were therefore not observed. Because of ceiling effects, no light was shed on the effectiveness of HHC or CONV training, either of which may have been superior had the test been more difficult.

### Efficiency

Efficiency as used in this evaluation refers to efficient use of students' time. Similar amounts of time were available for both groups to practice and perform drills, but objective records of amounts of practice by the two groups were, as noted earlier, not obtained. Differences between the two groups' efficiency in learning the Annex C material cannot, therefore, be accurately estimated. This, of course, considers only the effects of using the HHC on the test scores, and does not take into account possible benefits derived from the HHC students' learning how to use a small computer. Evaluation of such effects was beyond the scope of this project.

One question bearing on the students' use of time, and one which might have had an effect on the Annex C test scores, is whether the students used the HHC for at least the suggested amount of time. Students in the HHC group were instructed to use the HHC for 12-18 minutes for each kind of problem. Figure 1 presents the amount of time students reported using the HHC for each kind of problem.<sup>4</sup>

---

<sup>4</sup>Figure 1 shows six kinds of problems rather than the 11 mentioned earlier, because similar kinds of problems were combined to make students' time estimation easier. "Decimal to binary conversion," for example, includes "binary to decimal conversion" in Figure 1.

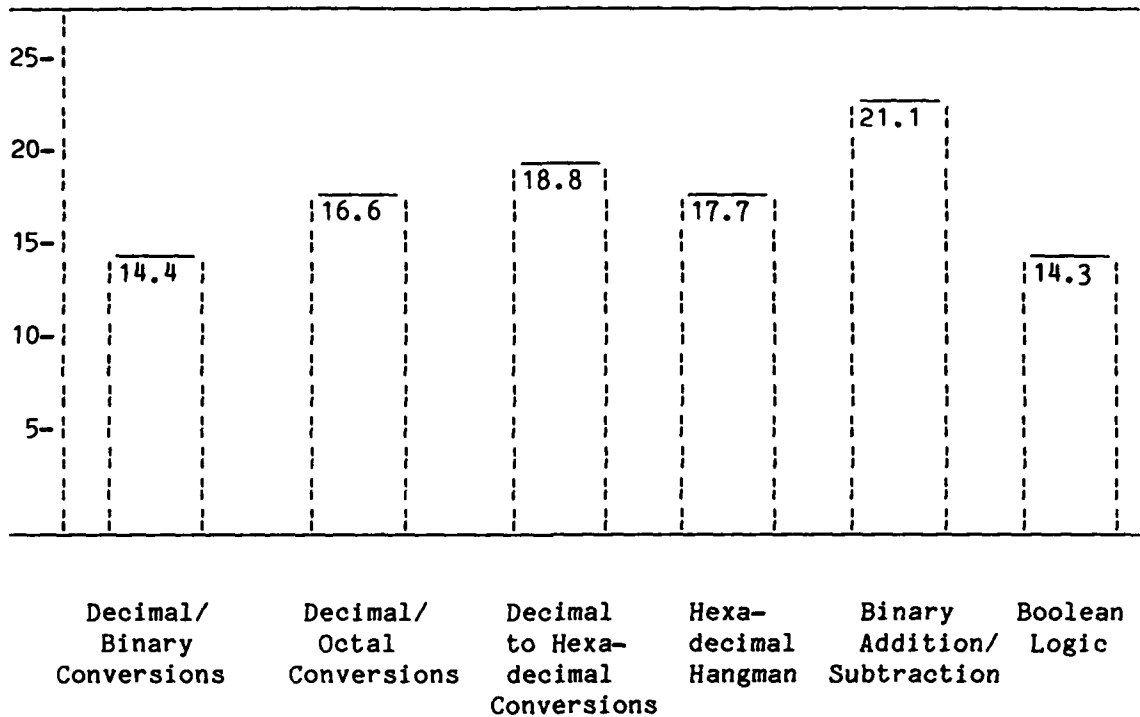

Figure 1. Mean time (in minutes) reported to have been spent by the HHC students (n=30) on each kind of practice problem.

As can be seen in Figure 1, the HHC students reported using the HHC for more than the suggested minimum (12-minute) amount of time for each kind of practice problem. Practice records for the HHC group also indicated that 28 of the 30 students solved problems at the highest difficulty level for each of the 11 kinds of problem. That increased practice would have increased the HHC group's scores on the end-of-annex test therefore seems unlikely. Whether decreased practice would have decreased scores cannot be determined.

#### User Acceptance

Table 1 shows the stems of seven questionnaire items which addressed students' acceptance of the HHC, and the percents of students responding in each rating category. Here it can be seen that 80 to 96.6 percent of the students responded in the two most positive categories for the seven questions.

The least positive ratings were given in response to item 7: "When you used the computer, how did it affect the use of your time during the annex?" These ratings were consistent with open-ended question 2, which asked, "What did you dislike about using the computer in this annex?" Fifty-seven percent of the students commented that the HP-41CV was too slow. The computer's response time was reported as the only drawback of any importance, although 80 percent of the students indicated the HHC made "better" or "much better" use of their time (Table 1, item 7).

HHC students also were asked an open-ended question (item 1) about what they liked about using the computer. Table 2 summarizes the positive responses in which 10 percent (n=3) or more of the students made similar comments.

TABLE 1  
PERCENTS OF STUDENTS (N=30) RESPONDING IN EACH RATING CATEGORY FOR  
QUESTIONNAIRE ITEMS 5 THROUGH 11 (1 = HIGHEST, 5 = LOWEST)

ITEMS	RATINGS				
	1	2	3	4	5
5. When you used the computer, how much do you think you learned compared with other learning activities?	43.3	46.7	10.0	0.0	0.0
6. When you used the computer, how fast do you think you learned compared with other learning activities?	40.0	46.7	13.3	0.0	0.0
7. When you used the computer, how did it affect the use of your time during the annex?	30.0	50.0	13.3	6.7	0.0
8. How interested were you in going through the practice exercises on the computer?	70.0	26.7	3.3	0.0	0.0
9. How often did you try to get to the highest difficulty level of the practice exercise?	86.7	10.0	0.0	3.3	0.0
10. Would you like to use the computer for other training?	76.7	20.0	3.3	0.0	0.0
11. How would you advise a friend who had a choice between taking a course where there was a great deal of use of the computer or another course without the computer?	56.7	40.0	3.3	0.0	0.0

TABLE 2

PERCENTS OF STUDENTS (N=30) RESPONDING IN VARIOUS CATEGORIES TO THE QUESTION, "WHAT DID YOU LIKE ABOUT USING THE COMPUTER IN THIS ANNEX?"

Responses	Percents
Learned More	27
Received More Practice	23
Easier to Learn	17
Good Feedback/Quick Feedback	13
New or Fun to Use	13
Easy to Use	10
Liked Self-Pacing	10

HHC group students were asked to rate the usefulness of the HP-41CV for each of the eleven kinds of practice exercises mentioned earlier. Students were, as can be seen in Figure 2, positive in their responses: mean ratings on a scale of from 1 to 10 ranged from 8.5 to 9.1.

The questionnaire completed by the instructor is presented with his responses in Appendix E. The instructor reported that students' learning, confidence, attention, and efficient use of time were increased when using the HHC compared to the paper-and-pencil method. He also reported that use of the HHC in training made him more available to help students.

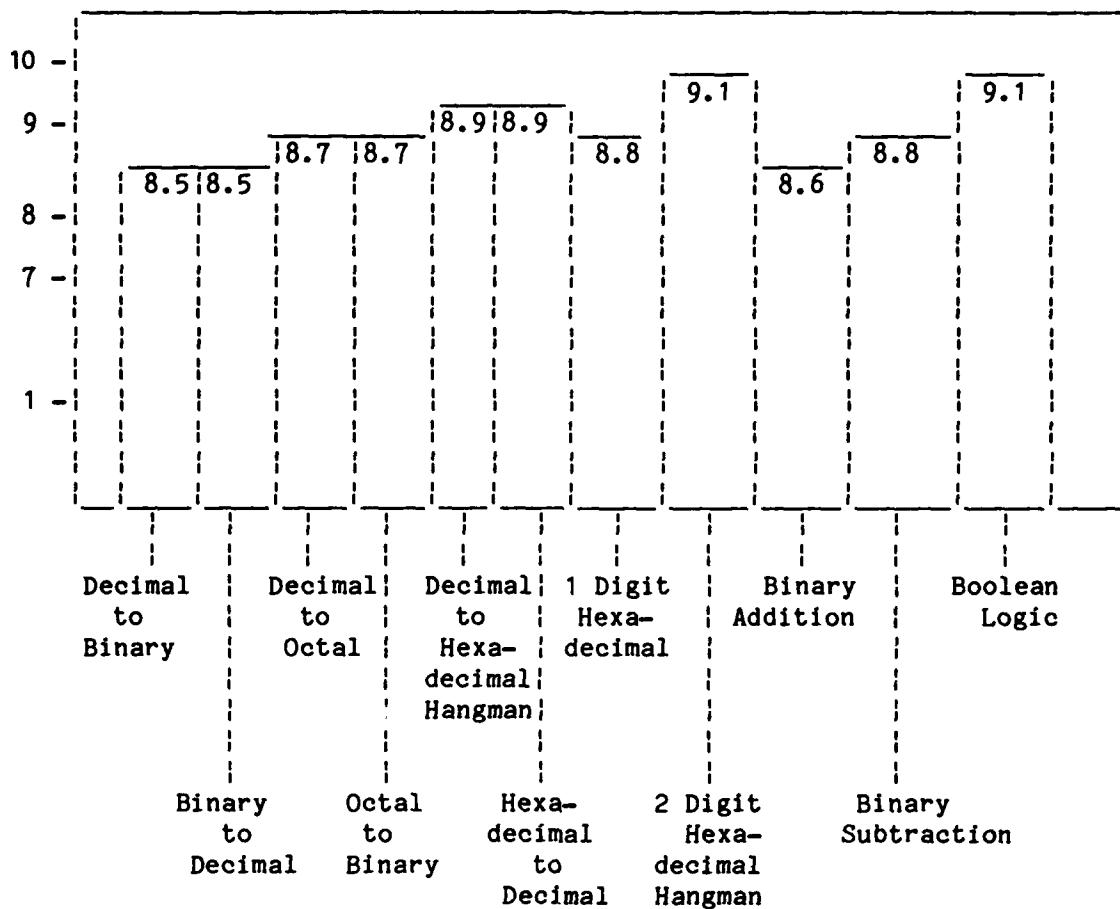

Figure 2. HHC group's ratings of the usefulness of the 11 kinds of practice exercises. (Ratings are on a scale of 1 = "not useful" to 10 = "useful.")

The instructor "strongly disagree(d)" with the statement, "I would like to see the HHC used in other annexes in this course," and noted that this was because of the "technical aspects of the rest of the course." That is, the instructor thought that the other subject matter in the course was not appropriate for HHC applications.

#### Quality of Implementation

Few problems seem to have occurred in implementing HHC training, although two cases of equipment malfunction were reported.

Two members of the HHC group volunteered comments about the instructor. Both comments were positive.

### Reliability

Two hardware malfunctions were logged during Annex C training. Both were described as "major." One of the Boolean algebra problems also was reported not to have functioned approximately 20 percent of the time. Because of the small number of malfunctions, the brevity of use, and the lack of exact data on hours of use, traditional reliability estimation statistics (mean time between failure, for example) were not computed.

### Cost

The list price of the HP-41CV was 325 dollars in 1982. Retailers contacted during the writing of this report quoted prices of 260 to 275 dollars per unit. Organizations anticipating acquiring such devices should, of course, consider all costs associated with the new instruction, including peripherals, new software development and installation, hardware and software maintenance, and overhead; and those costs should be compared to the costs of conventional instruction. Available data did not permit such comparisons during the present study.

## **SUMMARY**

The purpose of this research was to estimate the user acceptance, efficiency, reliability, implementation quality, cost, and effectiveness of the Hewlett-Packard HP-41CV as used for teaching mathematics to Fire Control Systems Repairers.

### User Acceptance

Students' responses to questionnaire items about the acceptability of the HP-41CV were mainly positive. Eighty percent of the HHC group reported, for example, that the HHC made "better use" or "much better use" of their time. Fifty-seven percent, however, noted that the computer was "too slow" in accepting their answers and displaying new problems.

The HHC also was acceptable to the instructor, as indicated by his reports that students' learning, confidence, attention, and efficient use of time were increased by using the HHC as compared to the CONV method; and that using the HHC in training made him more available to help students.

### Efficiency

The HHC students reported having spent at least the recommended amount of time (12 minutes) practicing each kind of problem. Comparable data were not available for the CONV students, and objective measures of amount of practice were unavailable for either group. Estimating the HHC group's efficiency, either in some absolute sense, or relative to the CONV group, was therefore impossible.

### Reliability

The instructor reported two "major" malfunctions, and one algebra problem that did not work 20 percent of the time. Insufficient data were available, however, for making conventional estimates of reliability; mean time between failures, for example.

### Implementation Quality

Two students volunteered comments about the instructor. Both comments were positive. Additional data bearing on implementation quality were not available.

### Cost

Available data were insufficient for estimating the cost of HHC and CONV training.



## Effectiveness

Several factors precluded assessing the effectiveness of either HHC or CONV training:

1. No Control Group. Estimating the amount of proficiency due to training (that is, "training effectiveness") requires comparing trained people's end-of-training scores to the scores of untrained people. The untrained people can be a separate no-training control group, or the HHC and CONV group before training begins. Neither end-of-course scores for a no-training control group, nor pretraining scores for the HHC and CONV groups were obtained in this study. The amount of proficiency ascribable to training could not, therefore, be determined.

2. Unknown amounts of practice. This evaluation did not permit separating the effects of amounts of practice from the effects of using the HHC and CONV training. Whether the lack of differences between the two groups' end-of-training scores was due to using the HHC and conventional training, or to different amounts of practice by the two groups could not be determined.

3. Ceiling Effects. Detecting proficiency differences between two groups requires variance between the groups' scores. If the compared groups nearly "max" the test, as was the case in the present study, then variance is restricted, and possible differences are masked. Whether the training for the HHC and CONV groups was equally effective, or the test was not difficult enough to detect proficiency differences which did in fact exist between the groups could not be determined.

In summary then, the HP-41CV was acceptable to the students and instructor who used it for learning and teaching mathematics. The efficiency, reliability, implementation quality, cost, and effectiveness of using the device remain to be demonstrated.

## RECOMMENDATIONS

Limits on research resources demand that selectivity be exercised in deciding what to evaluate. Recommended priorities for evaluations such as the one reported here are, from lowest to highest:

1. User acceptance: Research on user acceptance should be reserved for diagnosing ineffective programs of instruction. The importance of research on user acceptance depends upon whether the instructional program is ineffective or effective. If the program is ineffective, and one wants to know why, then user acceptance may be among the issues that should be examined. If a program is effective, then user acceptance may be assumed to be either sufficient or irrelevant. Whether a course is effective or ineffective should in any event be established before research on user acceptance is undertaken.

2. Implementation quality: Research on implementation quality should, like research on user acceptance, be reserved for diagnosing ineffective programs of instruction. The considerations here are as they were for user acceptance: If one is interested in why a program is ineffective, then implementation quality may be an appropriate research issue. Effective programs, on the other hand, can be assumed to have been adequately implemented or insensitive to implementation quality. The effectiveness of the program should in any event be established before scarce resources are expended for implementation quality research.

3. Reliability: Research on the reliability of instructional delivery systems should be reserved for instances in which (a) a comparison case is available, or (b) the different actions that will attend different outcomes of the research are specified in advance. Objective data on delivery-system reliability are of little value alone. Knowing that a system's MTBF is X hours, for example, becomes valuable only when the MTBF (a) can be compared to similar data for something else (the reliability of the conventional training delivery-systems, for example, or a minimally acceptable reliability standard); or (b) leads to different actions (buying or not buying the system, for example).

4. Efficiency: Instructional efficiency can be computed from data on the cost and effectiveness of instruction. Measuring efficiency therefore requires no research other than that required for measuring cost and effectiveness. Efficiency of instructional systems is as it is for other systems: a set of numbers which reflects how much is put into the system relative to how much comes out. Input for training systems may include amount of training time, and all other instructional resources whose prices can be estimated. Input for training systems is price, and is appropriately expressed in dollars. The output of training systems is proficiency, which is expressed in terms of amount learned. There are, unfortunately, no "units" of amount learned, which can only be expressed in relative terms; percent improvement, for example, or percent of maximum

possible performance. Input dollars may be divided into or by output percents to yield indexes of training efficiency or cost effectiveness. This is analogous, but by no means identical, to unit pricing in supermarkets. It is analogous in that price in both cases may be divided by the amount of "what you get." It is not comparable because pounds, ounces, and other weights and measures used by supermarkets are absolute: a pound is a pound irrespective of what is measured. This is not the case with amount learned, which as mentioned earlier, is relative: a 20 percent improvement in Course X is unlikely to be "the same as" a 20 percent improvement in Course Y, or for that matter in Course X measured at another time.

5. Cost: Savings due to using new instructional programs should be estimated before research is conducted to measure the programs' effectiveness. If the case for savings due to the new program is not compelling on rational (prospective) grounds, then little will be gained by empirical research on the costs and effectiveness of alternatives.

6. Effectiveness: Research designs for examining the effectiveness of instructional programs should insure that:

(a) Test scores for untrained persons are obtained, against which the scores of trained persons can be compared. If this is not done, then the amount of proficiency ascribable to training will not be determinable.

(b) Records are kept of the amounts of practice by each member of the compared groups. If this is not done, then *determining whether* proficiency differences between groups were due to kinds of training or to amounts of training will not be possible.

(c) End-of-course tests are difficult enough to reveal differences between good and mediocre performances. If this is not done, then proficiency differences between the compared groups may be masked.

Recommendation 6 can be implemented by using an experimental design in which each compared group is divided into three subgroups, one of which gets no training, another of which gets the usual amount of training, and another which gets an amount between the usual and none. All groups are then tested on a multiple-item proficiency test. Such a design hedges against ceiling effects, uses a no-training control group, and separates the effects of amount of training from the effects of training media.



#### REFERENCES

- Francis, L. D., & Levy, G. W. (1982). An evaluation of the feasibility of using hand-held computers for training. Fort Monroe, VA: U.S. Army Training and Doctrine Command.
- Rose, A. M., Wheaton, G. R., Leonard, B. L., Jr., Fingerman, P. W., & Boycan, G. G. (1976). Evaluation of two tank gunnery trainers (ARI Research Memorandum 76-19). Alexandria, VA: U.S. Army Research Institute for the Behavioral and Social Sciences. (AD A082 954)



APPENDIX A

INSTRUCTOR MANUAL FOR HP-41 COMPUTER LESSON

Do's and Don't's for HP-41-Using Instructors

1. Read the student Supplement first; then read all the notes here before starting.
2. Never unplug the card reader, the printer, or the modules from the back (top?) of the computer while the computer is on. We haven't tried it, but the manual warns of dire consequences.
3. When loading cards into the computer, always pull the last card out before inserting the next card. The second card will NOT bump out the first, but will jam impressively.
4. Whenever you do something to the computer, the PRGM message should be off. From time to time, while it is calculating, PRGM will be on, but before you are to do anything (e.g., read cards, enter info), the PRGM message will go out. If cards are read in while PRGM is on, the program on the cards will probably be erased.

Setting up a computer for the first time or  
Reloading a computer with a different drill

To ready the computers, do the following:

1. Load batteries (and charge, if rechargeable).
2. Turn computer off.
3. Place the XFTN in port #1 of the computer. Computer should always be off when XFTN is inserted or removed. (Re-initialization will be needed if XFTN is moved from one computer to another. This should never be necessary.)
4. Attach the card reader.
5. Find the keyboard overlay template packed with each computer. Use a pen to mark it like the example shown below.

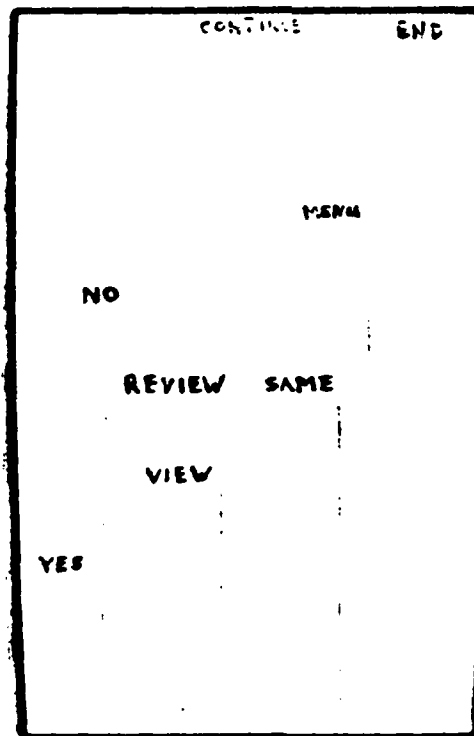



6. Clear out all programs in main memory:  
With the computer off, hold down the "+" key and keep it held down while you press ON. Release "+" and see the message "memory lost".
7. Adjust the number of registers as follows: XEQ, ALPHA, SIZE (spell this out), ALPHA, wait a second, type "100".
8. Now begin loading programs. Whenever you do something to the computer with programs BATTELLE has written, the PRGM message should be off. From time to time, while it is calculating, PRGM will be on, but before you are to do anything (e.g., read cards, enter info), the PRGM message will go out. If cards are read in while PRGM is on, the program on the cards will probably be erased.  
  
The first program to be loaded will always be "RAN". Press: GOLD-GTO-.-. and put the card labeled "RAN" into the right side of the card reader with the #1 end of the card going in first. When fed through, pull it out and replace it in the holder.
9. There are six different sets of drill programs.  
  
We suggest you load three computers with each set of drills. It is possible to delete and reload programs to adjust the number of computers of each type available to students. You just follow the directions above starting with step #6. The two remaining computers can be used for slow drills or as spares. Make a paper label for each computer (e.g., "#1 Binary") and place it in the slot on the top of the card reader.
10. Most of the drills require three programs; a program which "runs" a pair of drill exercises, a program to generate random numbers, and a program which generates a particular problem for a drill. The problem generator should be loaded second since the drill program (loaded last) must be deleted to make room for the instructor's program when a student is done. The names of the programs and the way they will fit in memory are:

<u>Function</u>	<u>Permanent</u>	<u>Problem</u>	<u>Drill (LIFO)</u>
#1 Binary Drill	RAN	BGEN	D12
#2 Octal Drill	RAN	OGEN	D34
#3 Hex Drill	RAN	HGEN	D56
#4 Hex-Binary Drill	RAN	BHGN	D78
#5 Add-Sub Drill	RAN	BGEN	D90
#6 Boolean Drill	RAN	Special*	D11
Instructor Data Dump	RAN	(Leftover)	INSTR

\* See below.

When loading a program, remember to press GOLD - GTO - . . . before each whole program (1 or more cards with the same name) is loaded. If you don't, the computer will say "Nonexistent" when you try to execute.

When feeding cards in, remember that most generally are fed in twice, once from each direction. Which end first or which card first doesn't really matter to the computer, but it's confusing if you don't do them in order. The computer will ask for any missing cards by number. Always check to see if the display reads "CARD ERR" after the card is fed through. If so, re-insert. If you get card err twice in a row, use the special head cleaning "card" once. Use this only when you are having problems. The cleaning card is abrasive and should not be used unless necessary. Always pull out the last card before inserting the next card. The second card will NOT bump out the first, but will jam impressively.

To Summarize:

If you wanted to load a computer labeled #1 Binary, you would

- a) assemble the computer
- b) clear all memory and see "memory lost"
- c) adjust SIZE
- d) type GOLD - GTO - . . .
- e) feed in RAN card - one direction only
- f) type GOLD - GTO - . . .
- g) feed in cards for BGEN
- h) type GOLD - GTO - . . .
- i) feed in D12
- j) check to see that D12 executes (more about that later).

11. Special instructions for loading computer #6 Drill D11.

- a) GOLD - GTO - . . .                      b) then load RAN.
- c) then GOLD - GTO - . . .
- d) Next, load D112
- e) Then put the name D112 into the alpha register (Press ALPHA, GOLD, CLX/A, D, GOLD 1, GOLD 2, ALHPA).
- f) Then XEQ, ALPHA, SAVEP, ALPHA, wait. This procedure loads D112 into the XFTN module.
- g) Now delete D112 from main memory: XEQ, ALPHA, CLP, ALPHA, ALPHA, D112, ALPHA.
- h) GOLD - GTO - . . .
- i) Next load D11.
- j) GOLD - GTO - . . .
- k) Load D111. D11 will delete D111 and load D112 at the appropriate time.

12. The INSTR program always readies the computer for the next student. The first time the computer is used, however, a special initialization is needed. To initialize: type "0", STO, type "01" and wait a second. When this is done, the computer gets ready to zero some internal student data counters when the drill is next executed. When fully initialized and the drill is executed, the computer will always ask for the student number. After the number is entered, the computer will display, "READY..."

13. To make the computer automatically execute the drill as soon as it is turned on, do the following:
  - a) GOLD, 7 (causes "SF" to be shown), then type 11.
  - b) GOLD, GTO, ALPHA. program name (e.g., D11), ALPHA
  - c) Turn the computer off
  - d) This feature is called "auto-start".
14. Prepare the classroom by:
  - a) finding a place for the printer, problem log, batteries, rechargers, etc.
  - b) check labeling of the computers
  - c) verify a supply of Annex C, Supplement 2 is ready
  - d) By using an adhesive page or by disassembling and reassembling student guide, correct the learning activities list.

#### Normal Day-to-Day Training Operations

1. Read the student Supplement first; then read all the notes here and in the "Set Up" section before starting.

The order of events in a classroom is typically:

2. The student reads some directions.
3. The student requests a computer from you by its number. You turn on the computer. It beeps to let you know auto-start worked.
4. You enter the student's number from the sheet on the instructor's desk or you add a new student's name next to the first unassigned number. The computer replies "READY..."
5. You hand the computer to the student.
6. The student hands the computer back to you after 15-20 minutes. Its display says "Instructor". You hit R/S.
7. You delete the drill: XEQ, ALPHA, CLP, ALPHA, ALPHA, drill name, ALPHA.  
Note: For Computer #6, Boolean Algebra, you only delete D112.

8. You type GOLD - GTO - . - . and load the program named INSTR from cards. The computer will autostart in the printing program.
9. You turn off the computer, remove the "dummy" plastic module (leaving the cardreader in place), plug in the printer, turn it on.
10. You turn on the computer and, only if auto-start does not work, hit XEQ, ALPHA, INSTR, ALPHA to execute the instructor program.
11. If the printing went well, you type "Y" when the computer asks to zero the results.
12. You turn the computer and printer off, remove the printer plug, replace the "dummy" module, and turn the computer back on.
13. You delete the instructor program: XEQ, ALPHA, CLP, ALPHA, ALPHA INSTR, ALPHA.
14. You load the drill back in: GOLD - GTO - . - . and feed in the cards. Note: for D11, you need load D111 only.
15. The computer will auto-start so that it requests the student number. If not, enter: XEQ, ALPHA, program name (e.g., D11), ALPHA. You could also do step 13 on page 6 of these directions, but the above is shorter. Because the auto-start feature will make the computer execute the drill just loaded, you may (especially for computer #6) have the computer executing the wrong program (D111 instead of D11). This will not harm anything but will produce weird displays (e.g. numbers with two decimal points). To halt the execution in these cases, press R/S right after loading.
16. Turn the computer off, and place it on the shelf until needed by the next student.

Hints and guidelines about other things  
that might happen and further details  
about the computer's operation

17. To repeat: Only the last program (labeled LIFO on the chart on page 4) must be deleted to load INSTR for computers 1 - 5. For computer 6, delete only D111. Other programs you have loaded will automatically be called by the computer when needed.
18. When the student's computer doesn't say "INSTRUCTOR" when it's handed to you at the end of a session, hit "9" on the index. (Note that all values other than 1, 2, and 9 recycle the index.) "9" on the index causes a display of "FINISHED--SEE INSTRUCTOR". Once you have that display, press R/S.
19. To execute the program that does not automatically execute after pressing ON: hit XEQ key, ALPHA, spell out the name, hit ALPHA, wait for the duck to quit flying. Program names are:\*

D12	- Binary	#1
D34	- Octal	#2
D56	- Hexadecimal	#3
D78	- Binary - Hex	#4
D90	- Addition/Subtraction	#5
D11	- Boolean	#6
INSTR - Instructor Mode		

20. The printer plug goes in with the printing to the outside. The plug looks like it will go in another 1/16", but it won't. When turning the printer on, turn it all the way on -- there is a STANDBY position in the middle that could be confusing. See the appendix for sample printer output. If the printer won't work, you can still run the INSTR program and copy the data out by hand. Press R/S every time you get a blank line or when you want to continue. If the INSTR program for some reason won't load or execute, see the appendix of this document for a way to extract the data.

\* Numbers must be preceded by the GOLD key.

Never unplug the card reader, the printer, or the modules on the back (top?) of the computer while the computer is on. We haven't tried it, but the manual warns of dire consequences.

21. When feeding cards in, remember that most generally are fed in twice, once from each end. Which end first or which card first doesn't really matter to the computer, but it's confusing to the operator if you don't do them in order. The computer will ask for any missing cards by number.
22. At some time you may mistype a student number and press R/S. To re-enter a student number, without using INSTR, type 9 on the index, R/S, type 0, hit "STO" key, type "01", then execute the program.
23. If you want to run D11 more than once for a student, you need to delete D112 from memory, and load D111 between each run. There is never a need to load D112 into the XFTN module again unless the XFTN module is removed from the computer.
24. The HP runs a bit slowly. While it is running, the "duck" will be flying across the screen or the "PRGM" will be lit.
25. The "levels" of difficulty within a drill are based on the number of digits in the non-decimal base. Therefore, when viewing decimal values to be converted to another base, you may sometimes think the level has changed inappropriately, but it's really okay. For example, you change 101 to octal properly, then get a new problem that seems easier: 65. But, both are 3 digit numbers in octal.
26. A student should never need to use the 4 switches at the top: on/user/prgm/alpha.
27. Other duties that you as an instructor have with respect to the hand held computer project are:
  - a) Checking paper in the printer. See the manual for how to re-load paper.
  - b) Checking for "BATT" indicator on the computer and replacing or recharging batteries.
  - c) recharging the printer.
  - d) handing out and collecting the student evaluation sheets. They are completed right after the Boolean algebra drill.

- e) Writing down on the log any problems with the computer or the programs.
  - f) Reporting to Jim Dees any programming problem that threatens the chances of the computer experiment not working as intended.
28. The computer should normally auto-start correctly if the student does not turn off the computer in the middle of the drill. If the student or instructor turns the computer off at the very beginning of a drill (on the menu) or the computer turns off automatically (after 10 minutes) while on the main, the computer will auto-start just fine. The computer will sound a tone when it is turned on if it is going to auto-start. Should the computer accidentally be turned off and not auto-start, enter: XEQ, ALPHA, program name (e.g. D12), ALPHA.

As an instructor, you should only turn the computer off when it is set to the "Enter student number" display on the menu. No harm results if the computer gets turned off at other times, but you will have to use the XEQ key as above to start the program. One other interesting side-effect of using auto-start: when you load a program from cards (for example, INSTR or a drill), if auto-start is set, the newly-loaded program is immediately executed. In the case of INSTR, this means the computer will ask you to connect the printer. REMEMBER to turn off the computer before connecting the printer.

If auto-start is set and you have deleted the main program (INSTR or a drill), and then you turn the computer off and back on, the computer will try to restart in a nonexistent program. The results may be erratic, though not harmful to the computer. If this occurs, press R/S until the PRGM light disappears and a number appears on the display. Try to load the proper program and reset the auto-start via step 13, page 6.



## Appendix A

### Troubleshooting and Incidental Information

Troubleshooting (also see the Hewlett-Packard Manuals)

<u>Symptom</u>	<u>Problem</u>	<u>Solution</u>
No display	<ol style="list-style-type: none"> <li>1. Batteries low</li> <li>2. Battery pack not in good contact</li> <li>3. Program displaying blank line</li> </ol>	<p style="text-align: center;">-</p> <p style="text-align: center;">-</p> <p style="text-align: center;">R/S</p>
Computer: No Room	<ol style="list-style-type: none"> <li>1. Drill or Instructor Program not deleted</li> <li>2. No GTO,.. between programs</li> </ol>	<p style="text-align: center;">-</p> <p style="text-align: center;">Reload all</p>
Computer: Nonexistent	<ol style="list-style-type: none"> <li>1. Drill or generating programs not loaded</li> <li>2. Misspelled</li> </ol>	
Computer: Card Err	<div style="display: flex; align-items: center;"> <div style="font-size: 3em; margin-right: 10px;">}</div> <ol style="list-style-type: none"> <li>1. General Orneriness</li> <li>2. Dirty Reader</li> <li>3. Dirty Card</li> <li>4. Weak battery</li> </ol> </div>	<p style="text-align: center;">Always repeat once</p> <p style="text-align: center;">Special Red Card</p> <p style="text-align: center;">Soap and Water</p>
Computer: Checksum		
Computer: Data Err	<ol style="list-style-type: none"> <li>1. Invalid input</li> <li>2. Forgot to press ALPHA</li> </ol>	<p style="text-align: center;">R/S and repeat</p>

#### Standard Procedures

To Delete a program, hit: XEQ, ALPHA, CLP, ALPHA, wait, ALPHA, name of program, ALPHA, wait.

When loading a new program, remember to press GOLD - GTO - . - . before each whole program (1 or more cards with the same name) is loaded. If you don't, then the computer will say "Nonexistent" when you try to execute. Do NOT use this procedure after loading the last program.

### To Copy Magnetic Cards

1. Load the computer with the programs you want to copy.
2. Label the blank cards with the program name, date, and your initials.
3. XEQ, ALPHA, P-A-C-K, ALPHA.
4. GOLD, GTO, ALPHA, program name, ALPHA.
5. There may be a brief pause, then the display will return to whatever it was before.
6. Press PRGM (on the top row of four keys) and, if all has been done correctly, you will see, for example: 01 LBL  $\uparrow$  RAN if your program name was RAN. Ignore the two digits.
7. Take the card you labeled RAN in step #2 above and put it in the card reader with the #1 end first. Remove it and put the #2 in, if prompted by the computer.
8. The computer will prompt you for which card/side to insert until the whole program is copied. Be sure you have the right end of the right card, because the computer doesn't care and will overwrite blissfully.
9. When one program is completely copied, you can repeat step # 7 with more labeled blank cards.

When loading cards, remember that most cards are fed through twice -- once from each direction. Always check to see if the display reads "CARD ERR" after the card is fed through. If so, re-insert. If you get CARD ERR twice in a row, use the special head cleaning "card" once.

So that you can debug some problems yourself, here is a way to look at data without using INSTR. This technique can also be used if the INSTR program fails.

To view the collected student data, press RCL, then type the two digit code shown at the left on the following table for the data you want. Continue pressing RCL and giving codes until you have all the data you need.

- 00 - # of First\* Drill
- 01 - Student ID #
- 02 - # Problems Given for Drill "A"
- 03 - Highest Level Reached Drill "A"
- 04 - # Problems Given for Drill "B"
- 05 - Highest Level Reached Drill "B"
- 06 - # Problems Missed for Drill "A"
- 07 - # Problems Skipped for Drill "A" (i.e., returns to index)
- 08 - # Problems Missed for Drill "B"
- 09 - # Problems Skipped for Drill "B"
- 10 - Current Seed for Random Number Generator

\*i.e., if D56 is loaded, this value will be "5".

STUDENT NUMBER: 15.

SCORES FOR DRILL 11.

NUMBER OF PROBLEMS  
GIVEN: 25.  
MISSED: 4.  
SKIPPED: 1.

HIGHEST LEVEL: 6.

STUDENT NUMBER: 18.

SCORES FOR DRILL 9.

NUMBER OF PROBLEMS  
GIVEN: 22.  
MISSED: 2.  
SKIPPED: 2.

HIGHEST LEVEL: 8.

SCORES FOR DRILL 10.

NUMBER OF PROBLEMS  
GIVEN: 17.  
MISSED: 7.  
SKIPPED: 2.

HIGHEST LEVEL: 8.

STUDENT NUMBER: 15.

SCORES FOR DRILL 1.

NUMBER OF PROBLEMS  
GIVEN: 25.  
MISSED: 4.  
SKIPPED: 1.

HIGHEST LEVEL: 6.

SCORES FOR DRILL 2.

NUMBER OF PROBLEMS  
GIVEN: 35.  
MISSED: 8.  
SKIPPED: 2.

HIGHEST LEVEL: 8.

SAMPLE PRINTER OUTPUT

## LEARNING ACTIVITIES

1. This exercise is printed in Programmed Instruction (PI) format. Read and perform all required actions in the top section of all pages first, then the middle section, and finally the bottom section. Contact your instructor if you need clarification. Correct answers for the blanks are on the back of the same page.
2. Read FM 11-72, pages 2-1 to 2-8 only (up to, but not including, "Octal").
3. Go to page 2 of Annex C, Supplement 2, and follow the directions there.
4. Read FM 11-72, pages 2-9 to 2-11 (up to, but not including, "Hexadecimal").
5. Go to page 7 of Annex C, Supplement 2, (titled "Octal") and follow directions there.
6. Read FM-72, pages 2-11 and 2-12 (up to, but not including, "Binary Coded Decimal").
7. Go to page 9 of the Annex C, Supplement 2, (titled "Hexadecimal") and follow the directions there.
8. Read FM 11-72, pages 2-16 to 2-18 only.
9. Go to page 11 of the Annex C, Supplement 2 and follow the directions there.
10. Read FM 11-72, pages 2-20 (starting at "subtraction") and 2-21 (stop at the bottom of the page).
11. Go to page 12 of the Annex C, Supplement 2, and follow the directions there.
12. Read the following pages from FM 11-72:
  - 2-12 to 2-16
  - 2-19 to 2-20
  - 2-22 to 2-27
13. Have the instructor give you the Exercise Examination.
14. When you have achieved a GO on the examination, have the instructor initial and date the Student Progress Chart (located on page 2), then proceed to Exercise II which begins on page 17 of this manual.

## LEARNING ACTIVITIES

1. This exercise is printed in Programmed Instruction format. Read and complete all required actions. If you need clarification, contact your instructor.
2. Read FM 11-72, pages 3-1 to 3-12 only.
3. Go to page 13, Annex C, Supplement 2, (titled "Boolean Algebra") and follow the directions there.
4. Have the instructor give you the Exercise Examination.
5. Ask your instructor for the "Computer Evaluation Questionnaire". Complete it while your instructor grades your test.
6. When you have achieved a GO on the examination, have the instructor initial and date the Student Progress Chart (located on page 2), then proceed to Exercise III which begins on page 33.

APPENDIX B

EXCERPTS FROM THE PROGRAM OF INSTRUCTION, "COURSE 113: 45G10, FIRE CONTROL SYSTEMS REPAIRER" (INCLUDES POI FOR ANNEX C, "BASIC DIGITAL CIRCUITS")

PREFACE

- A. COURSE NO: 113-45G10 (USA)  
COURSE TITLE: Fire Control Systems Repairer
- B. PURPOSE: To train enlisted personnel to perform direct and general support maintenance of computer, ballistics; laser rangefinders/designators; tank mounted thermal sights and related test equipment at skill level one of MOS 45G. MOS for which trained: Fire Control Systems Repairer (45G10).
- C. PREREQUISITES: Active Army, Reserve Component or USMC personnel. Score of 95 or higher in aptitude area EL. Twenty-three months or more of active duty required of active Army personnel after completion of the course. Security clearance required: Confidential.
- D. SCOPE: General electricity/electronics; basic digital circuits; precision soldering; DS/GS maintenance of ballistic computers, laser range finders/designators; tank mounted thermal sights and TMDE. Common maintenance subjects, i.e., publications, tools, maintenance forms, safety, maintenance discipline and soldier's manual orientation.
- E. LENGTH: Peacetime Mobilization  
22 weeks, 3 days 16 weeks, 2 days
- F. TRAINING LOCATION: US Army Ordnance Center and School  
Aberdeen Proving Ground, Maryland 21005

**COURSE SUMMARY**

**Course Title: Fire Control Systems Repairer, 113-45G10**

**Speciality: 45G10**

	<u>USA</u>		<u>USMC</u>	
	<u>Peacetime</u>	<u>Mobilization</u>	<u>Peacetime</u>	<u>Mobilization</u>
<b>Hours:</b>	1002	985	599	590

**Summary:**

	<u>USA</u>	<u>Hours</u>	<u>USMC</u>		<u>Annex</u>	<u>Page</u>
	<u>Peacetime</u>	<u>Mob</u>	<u>Peacetime</u>	<u>Mob</u>		
<b>A. Task Cluster Titles:</b>						
Orientation and Common Maintenance Subjects	21	21	15	15	A	7
Basic AC-DC Electronics	146	146	146	146	B	9
Basic Digital Circuits	48	48	48	48	C	15
Common Precision Soldering	82	82	82	82	D	17
Maintenance of Laser Observation Set AN/GVS-5	96(1)	96(1)	96(1)	96(1)	E	20
Marine Corps Peculiar Subjects	0	0	59	59	F	23
Maintenance of M60A3 Tank Fire Control System	235	235	0	0	G	29
Maintenance of Ground Laser Locator Designator AN/TVQ-2	105	105	0	0	H	31
Miscellaneous Subjects	46	46	20	20	I	32
End-of-Course Examination	16	16	7	7	J	33
<b>Subtotal</b>	<b>795</b>	<b>795</b>	<b>473</b>	<b>473</b>		



	<u>Hours</u>			
	<u>USA</u> <u>Peacetime</u>	<u>Mob</u>	<u>USMC</u> <u>Peacetime</u>	<u>Mob</u>
<b>B. Administrative Time</b>				
Inprocessing	12(2)	12(2)	12(2)	12(2)
Outprocessing	8	8	8	8
Commandant's Time	40	40	22	22
Open Time	30	30	12	12
Physical Readiness Training	113(3)	96(3)	68(3)	59(3)
Physical Readiness Testing	4(3)	4(3)	4(3)	4(3)
Subtotal	207	190	126	117
Total	1002(4)	985(4)	599(4)	590(4)

**C. Recapitulation**

1. Security classification: Confidential.

2. Type of Instruction

Conference	18.0	18.0	36.0	36.0
Television	13.3	13.3	12.3	12.3
PM (Printed Material)	15.7	15.7	11.2	11.2
Practical Exercise 1	479.4	479.4	256.4	256.4
Practical Exercise 2	122.1	122.1	95.1	95.1
Examination 1	112.1	112.1	33.1	33.1
Examination 2	15.1	15.1	10.6	10.6
Examination 3	19.3	19.3	18.3	18.3
Administrative Time	207.0	187.0	126.0	117.0
Total	1002.0	982.0	599.0	590.0

- (1) Three NBC tasks are integrated into training in this Annex. These hours are reflected in Annex E (Lsn 45G10-E1), but are not included in hours reflected in paragraph A above.
- (2) Includes eye examination in accordance with TM Med 279.
- (3) Physical Readiness Training and Testing will be accomplished before and/or after the academic day and is not included in the overall course length.
- (4) Total POI hours are completed by adding academic time, in and outprocessing time, Commander's time and open time and PT time. Total POI hours are not used to determine course length.

113-45610-FIRE CONTROL SYSTEMS REPAIRER COURSE SEQUENCE

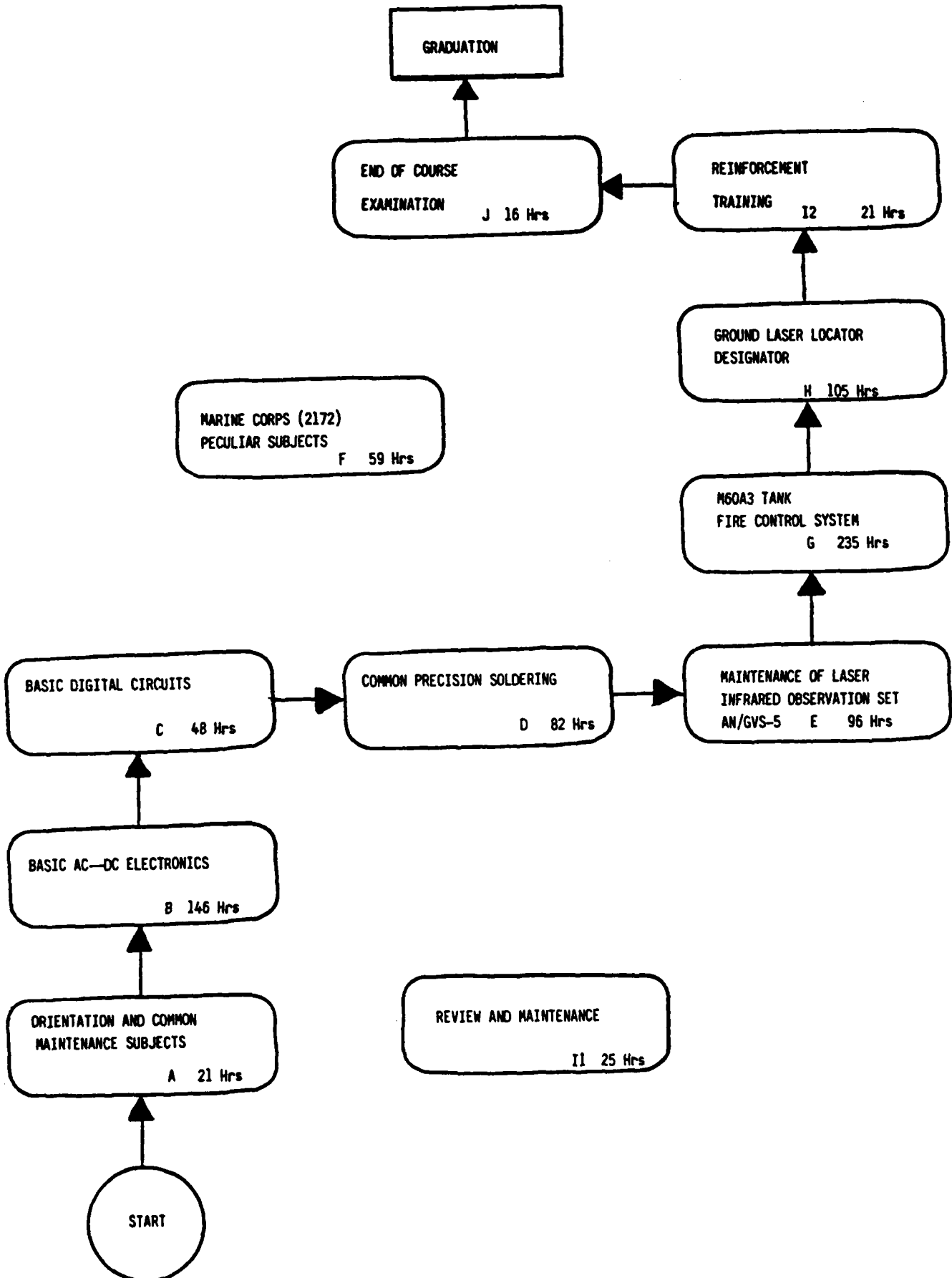

**Task Cluster Annex: C - Basic Digital Circuits**

**Purpose:** Student will demonstrate a knowledge of basic electronics and apply it to basic digital circuits.

	USA		USMC	
	<u>Peacetime</u>	<u>Mob</u>	<u>Peacetime</u>	<u>Mob</u>
<b>Total Hours:</b>	48	48	48	48

---

**POI File:** 45G10-C1 Binary System

**Type of Inst:** .4PM (1:20) 3PE2 (1:6) .6E3 (1 per class)

**Hours:** 4 4 4 4

**Objective:** Write correct responses given problems in the binary numbers system, without error.

**References:** FM 11-72

**POI File:** 45G10-C2 Boolean Algebra

**Type of Inst:** .4PM (1:20) 3PE2 (1:6) .6E3 (1 per class)

**Hours:** 4 4 4 4

**Objective:** Demonstrate a knowledge of boolean algebra, without reference or assistance, by writing and drawing correct responses to at least eight written questions.

**References:** FM 11-72

**POI File:** 45G10-C3 Diode Logic

**Type of Inst:** .4PM (1:20) 3PE2 (1:6) .6E3 (1 per class)

**Hours:** 4 4 4 4

**Objective:** Demonstrate a knowledge of diode logic gates, without reference or assistance, by writing and drawing correct responses to at least eight written questions.

**References:** TM 9-1220-221-34/1

	<u>USA</u> <u>Peacetime</u>	<u>Mob</u>	<u>USMC</u> <u>Peacetime</u>	<u>Mob</u>
<b>POI File:</b>	45G10-C4 Logic Trainer			
<b>Type of Inst:</b>	1PM (1:20)	25PE1 (1:3)	1E1 (1:3)	
<b>Hours:</b>	27	27	27	27
<b>Objective:</b>	Build and test a basic logic circuit, without assistance when given a logic trainer and required reference, the circuit will function without error.			
<b>References:</b>	FM 11-72, M4010 Digital Logic and Applications			
<b>POI File:</b>	45G10-C5 Logic Applications			
<b>Type of Inst:</b>	.5PM (1:20)	7.5PE2 (1:6)	1E3 (1 per class)	
<b>Hours:</b>	9	9	9	9
<b>Objective:</b>	Demonstrate a knowledge of logic mechanization and binary/octal/hexadecimal conversion, without reference or assistance, by writing and drawing correct responses to at least fifteen written problems.			
<b>References:</b>	FM 11-72 .			



APPENDIX C

END-OF-ANNEX C TESTS AND ANSWERS

ANNEX C EXERCISE

(Form A)

Student Name: \_\_\_\_\_

Date: \_\_\_\_\_

Convert the binary numbers below to their decimal equivalents.

1.  $1,011_2 = \underline{\hspace{2cm}}_{10}$

2.  $110,101_2 = \underline{\hspace{2cm}}_{10}$

3.  $10,111,101_2 = \underline{\hspace{2cm}}_{10}$

Convert the decimal numbers below to their binary equivalents.

4.  $12_{10} = \underline{\hspace{2cm}}_2$

5.  $39_{10} = \underline{\hspace{2cm}}_2$

6.  $221_{10} = \underline{\hspace{2cm}}_2$

Convert the octal numbers below to their decimal equivalents.

7.  $55_8 = \underline{\hspace{2cm}}_{10}$

8.  $466_8 = \underline{\hspace{2cm}}_{10}$

9.  $6362_8 = \underline{\hspace{2cm}}_{10}$

Convert the decimal numbers below to their octal equivalents.

10.  $31_{10} = \underline{\hspace{2cm}}_8$

11.  $186_{10} = \underline{\hspace{2cm}}_8$

12.  $2302_{10} = \underline{\hspace{2cm}}_8$

Convert the hexadecimal numbers below to their decimal equivalents.

13.  $B_{16} = \underline{\hspace{2cm}}_{10}$

14.  $C3_{16} = \underline{\hspace{2cm}}_{10}$

15.  $BCE_{16} = \underline{\hspace{2cm}}_{10}$

Convert the decimal numbers below to their hexadecimal equivalents.

16.  $14_{10} = \underline{\hspace{2cm}}_{16}$

17.  $214_{10} = \underline{\hspace{2cm}}_{16}$

18.  $3755_{10} = \underline{\hspace{2cm}}_{16}$

Convert the hexadecimal numbers below to their binary equivalents.

19.  $A_{16} = \underline{\hspace{2cm}}_2$

20.  $F7_{16} = \underline{\hspace{2cm}}_2$

21.  $DB_{16} = \underline{\hspace{2cm}}_2$

Convert the binary numbers below to their hexadecimal equivalents.

22.  $1,100_2 = \underline{\hspace{2cm}}_{16}$

23.  $11,100,101_2 = \underline{\hspace{2cm}}_{16}$

24.  $10,101,011_2 = \underline{\hspace{2cm}}_{16}$

Add the binary numbers as indicated.

25. 
$$\begin{array}{r} 1,011 \\ + \underline{1,110} \end{array}$$

26. 
$$\begin{array}{r} 110,101 \\ + \underline{111,101} \end{array}$$

27. 
$$\begin{array}{r} 11,011,101 \\ + \underline{10,101,111} \end{array}$$

Subtract the binary numbers as indicated.

28. 
$$\begin{array}{r} 1,101 \\ - \underline{1,010} \end{array}$$

29. 
$$\begin{array}{r} 111,001 \\ - \underline{101,011} \end{array}$$

30. 
$$\begin{array}{r} 11,110,011 \\ - \underline{10,101,111} \end{array}$$



Identify the Venn diagram corresponding to each of the following functions.

31.  $f = A\bar{B}$  Diagram No. \_\_\_\_\_

32.  $f = B$  Diagram No. \_\_\_\_\_

33.  $f = A + B$  Diagram No. \_\_\_\_\_

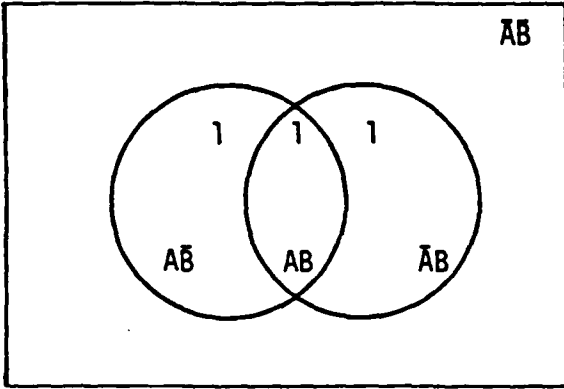

Diagram No. 1

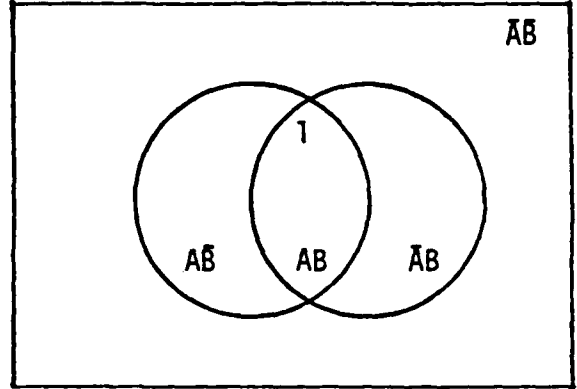

Diagram No. 2

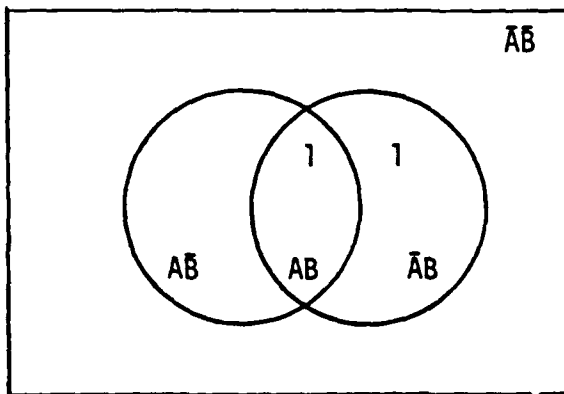

Diagram No. 3

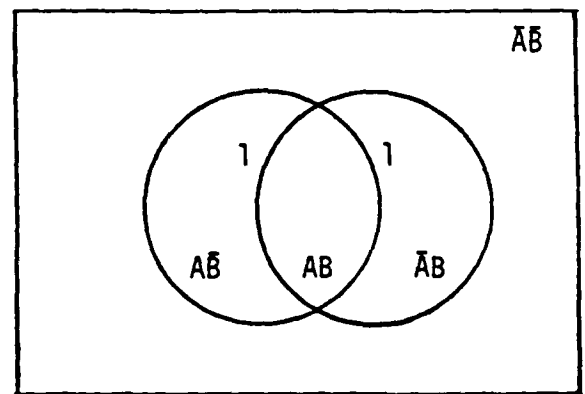

Diagram No. 4

Identify the circuit corresponding to each of the following functions:

34.  $f = A + B$                       Diagram No. \_\_\_\_

35.  $f = A$                               Diagram No. \_\_\_\_

36.  $f = AB$                              Diagram No. \_\_\_\_

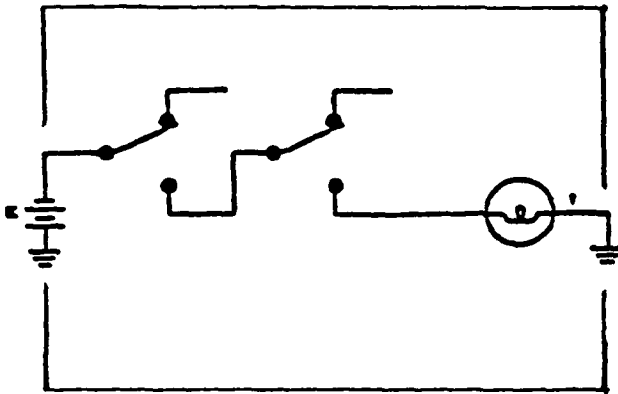

Diagram No. 1

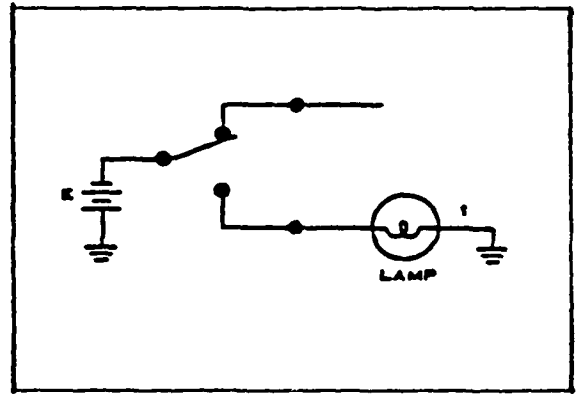

Diagram No. 2

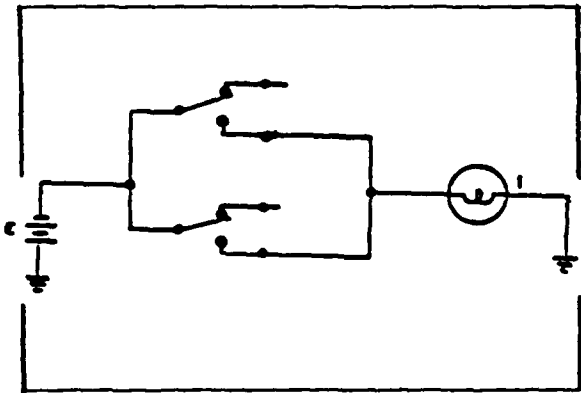

Diagram No. 3

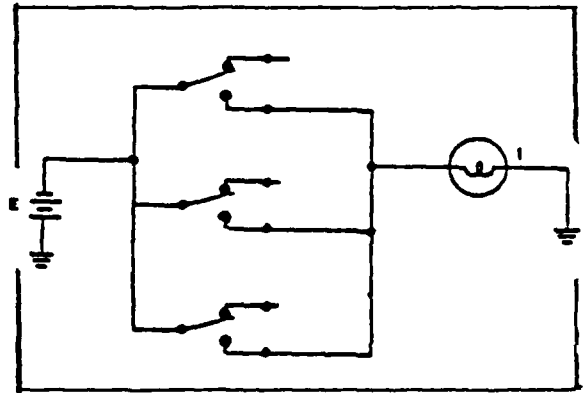

Diagram No. 4

ANNEX C EXERCISE  
(Form B)

Student Name: \_\_\_\_\_

Date: \_\_\_\_\_

Convert the binary numbers below to their decimal equivalents.

1.  $1,101_2 = \underline{\hspace{2cm}}_{10}$

2.  $111,101_2 = \underline{\hspace{2cm}}_{10}$

3.  $10,101,111_2 = \underline{\hspace{2cm}}_{10}$

Convert the decimal numbers below to their binary equivalents.

4.  $10_{10} = \underline{\hspace{2cm}}_2$

5.  $59_{10} = \underline{\hspace{2cm}}_2$

6.  $243_{10} = \underline{\hspace{2cm}}_2$

Convert the octal numbers below to their decimal equivalents.

7.  $43_8 = \underline{\hspace{2cm}}_{10}$

8.  $364_8 = \underline{\hspace{2cm}}_{10}$

9.  $5274_8 = \underline{\hspace{2cm}}_{10}$

Convert the decimal numbers below to their octal equivalents.

10.  $33_{10} = \underline{\hspace{2cm}}_8$

11.  $252_{10} = \underline{\hspace{2cm}}_8$

12.  $2676_{10} = \underline{\hspace{2cm}}_8$

Convert the hexadecimal numbers below to their decimal equivalents.

13.  $C_{16} = \underline{\hspace{2cm}}_{10}$

14.  $E4_{16} = \underline{\hspace{2cm}}_{10}$

15.  $CFD_{16} = \underline{\hspace{2cm}}_{10}$

Convert the decimal numbers below to their hexadecimal equivalents.

16.  $13_{10} = \underline{\hspace{2cm}}_{16}$

17.  $181_{10} = \underline{\hspace{2cm}}_{16}$

18.  $3564_{10} = \underline{\hspace{2cm}}_{16}$

Convert the hexadecimal numbers below to their binary equivalents.

19.  $F_{16} = \underline{\hspace{2cm}}_2$

20.  $A2_{16} = \underline{\hspace{2cm}}_2$

21.  $BC_{16} = \underline{\hspace{2cm}}_2$

Convert the binary numbers below to their hexadecimal equivalents.

22.  $1,011_2 = \underline{\hspace{2cm}}_{16}$

23.  $11,010,100_2 = \underline{\hspace{2cm}}_{16}$

24.  $11,101,100_2 = \underline{\hspace{2cm}}_{16}$

Add the binary numbers as indicated.

25. 
$$\begin{array}{r} 1,101 \\ + 1,010 \\ \hline \end{array}$$

26. 
$$\begin{array}{r} 111,001 \\ + 101,011 \\ \hline \end{array}$$

27. 
$$\begin{array}{r} 11,110,011 \\ + 10,101,111 \\ \hline \end{array}$$

Subtract the binary numbers as indicated.

28. 
$$\begin{array}{r} 1,110 \\ - 1,011 \\ \hline \end{array}$$

29. 
$$\begin{array}{r} 111,101 \\ - 110,110 \\ \hline \end{array}$$

30. 
$$\begin{array}{r} 11,011,101 \\ - 10,101,111 \\ \hline \end{array}$$

Identify the Venn diagram corresponding to each of the following functions.

31.  $f = A + B$                       Diagram No. \_\_\_\_

32.  $f = AB$                               Diagram No. \_\_\_\_

33.  $f = A$                                  Diagram No. \_\_\_\_

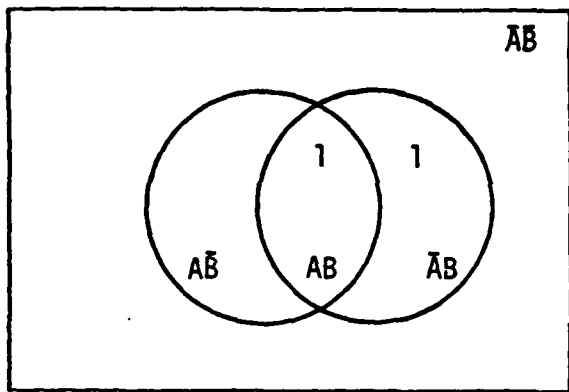

Diagram No. 1

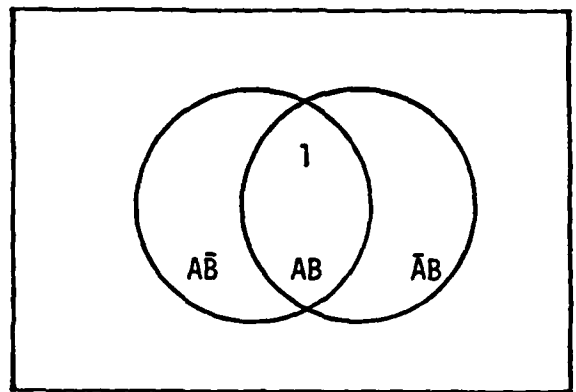

Diagram No. 2

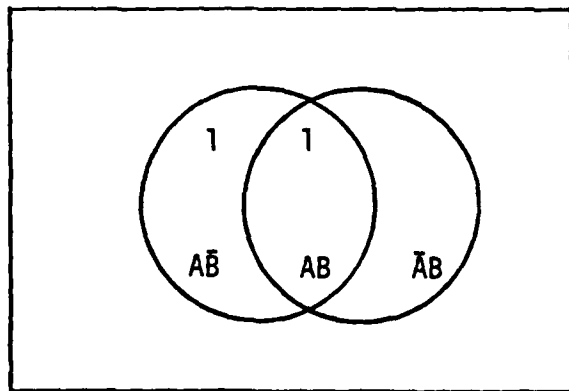

Diagram No. 3

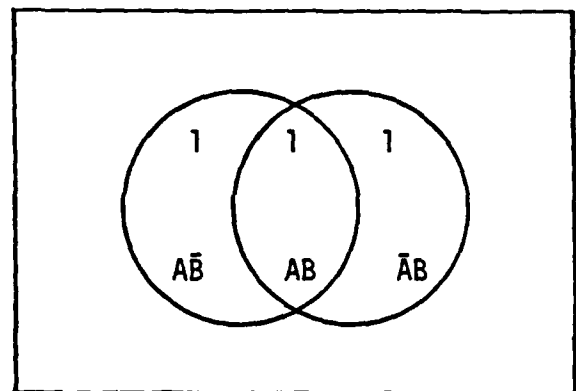

Diagram No. 4

Identify the circuit corresponding to each of the following functions:

34.  $f = AB$                       Diagram No. \_\_\_\_

35.  $f = A + B$                     Diagram No. \_\_\_\_

36.  $f = B$                          Diagram No. \_\_\_\_

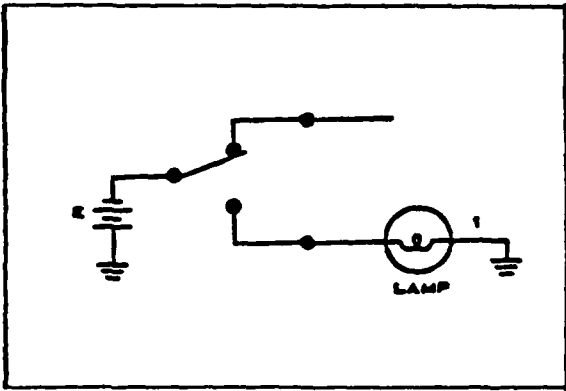

Diagram No. 1

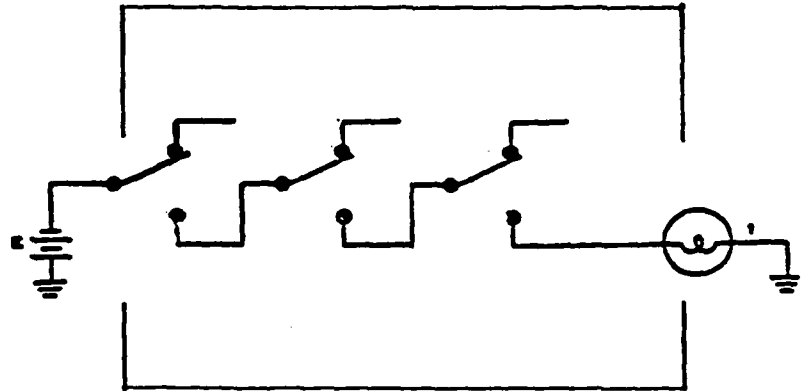

Diagram No. 2

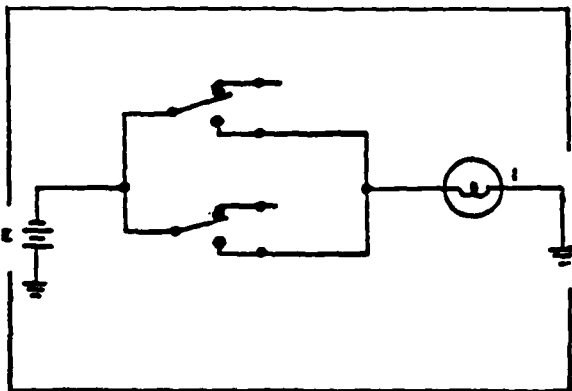

Diagram No. 3

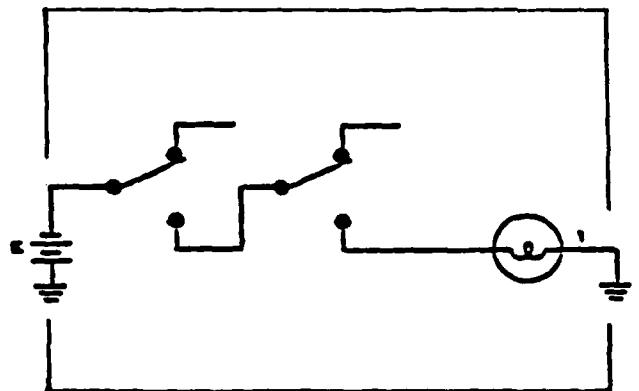

Diagram No. 4

ANNEX C EXERCISE KEYS

	<u>Form A</u>		<u>Form B</u>
1.	11 <sub>10</sub>	1.	13 <sub>10</sub>
2.	53 <sub>10</sub>	2.	61 <sub>10</sub>
3.	189 <sub>10</sub>	3.	175 <sub>10</sub>
4.	1,100 <sub>2</sub>	4.	1,010 <sub>2</sub>
5.	100,111 <sub>2</sub>	5.	111,011 <sub>2</sub>
6.	11,011,101 <sub>2</sub>	6.	11,110,011 <sub>2</sub>
7.	45 <sub>10</sub>	7.	35 <sub>10</sub>
8.	310 <sub>10</sub>	8.	244 <sub>10</sub>
9.	3,314 <sub>10</sub>	9.	2,748 <sub>10</sub>
10.	37 <sub>8</sub>	10.	41 <sub>8</sub>
11.	272 <sub>8</sub>	11.	374 <sub>8</sub>
12.	4,376 <sub>8</sub>	12.	5,164 <sub>8</sub>
13.	11 <sub>10</sub>	13.	12 <sub>10</sub>
14.	195 <sub>10</sub>	14.	228 <sub>10</sub>
15.	3,022 <sub>10</sub>	15.	3,325 <sub>10</sub>
16.	E <sub>16</sub>	16.	D <sub>16</sub>
17.	D6 <sub>16</sub>	17.	B5 <sub>16</sub>
18.	EAB <sub>16</sub>	18.	DEC <sub>16</sub>
19.	1,010 <sub>2</sub>	19.	1,111 <sub>2</sub>
20.	11,110,111 <sub>2</sub>	20.	10,100,010 <sub>2</sub>
21.	11,011,011 <sub>2</sub>	21.	10,111,100 <sub>2</sub>
22.	C <sub>16</sub>	22.	B <sub>16</sub>
23.	E5 <sub>16</sub>	23.	DA <sub>16</sub>
24.	AB <sub>16</sub>	24.	EC <sub>16</sub>

ANNEX C EXERCISE KEYS  
(Continued)

	<u>Form A</u>		<u>Form B</u>
25.	11,001	25.	10,111
26.	1,110,010	26.	1,100,100
27.	110,001,100	27.	110,100,010
28.	11	28.	11
29.	1,110	29.	1,000
30.	1,000,100	30.	101,110
31.	2	31.	4
32.	3	32.	2
33.	4	33.	3
34.	3	34.	4
35.	2	35.	3
36.	1	36.	1



APPENDIX D  
STUDENT QUESTIONNAIRE

*Please complete this form to the best of your ability so that the use of hand-held computers in this annex can be fully and fairly evaluated.*

Student Name: \_\_\_\_\_

Today's Date:                                
                    Day                    month                    Year

1. What did you like about using the computer in this annex? \_\_\_\_\_  
\_\_\_\_\_  
\_\_\_\_\_

2. What did you dislike about using the computer in this annex? \_\_\_\_\_  
\_\_\_\_\_  
\_\_\_\_\_

3. Rate the usefulness of each of the following computer practice exercises on a scale of 1 to 10:

	Circle One Number									
	Not Useful					Useful				
	1	2	3	4	5	6	7	8	9	10
a. Decimal to binary conversion	1	2	3	4	5	6	7	8	9	10
b. Binary to decimal conversion	1	2	3	4	5	6	7	8	9	10
c. Decimal to octal conversion	1	2	3	4	5	6	7	8	9	10
d. Octal to decimal conversion	1	2	3	4	5	6	7	8	9	10
e. Decimal to hexadecimal conversion	1	2	3	4	5	6	7	8	9	10
f. Hexadecimal to decimal conversion	1	2	3	4	5	6	7	8	9	10
g. One digit hexadecimal hangman	1	2	3	4	5	6	7	8	9	10
h. Two digit hexadecimal hangman	1	2	3	4	5	6	7	8	9	10
i. Binary addition	1	2	3	4	5	6	7	8	9	10
j. Binary subtraction	1	2	3	4	5	6	7	8	9	10
k. Boolean logic	1	2	3	4	5	6	7	8	9	10

4. The directions for each pair of drills suggested that you use the computer for 12-18 minutes. How long on the average did you in fact use it?
- a. Decimal to binary plus binary to decimal conversion \_\_\_\_\_ mins.
  - b. Decimal to octal conversion plus octal to decimal conversion \_\_\_\_\_ mins.
  - c. Decimal to hexadecimal conversion plus hexadecimal to decimal conversion \_\_\_\_\_ mins.
  - d. One digit hexadecimal hangman plus two digit hangman hexadecimal hangman \_\_\_\_\_ mins.
  - e. Binary addition plus binary subtraction \_\_\_\_\_ mins.
  - f. Boolean logic \_\_\_\_\_ mins.

*Please check the one response that best describes your opinion.*

5. When you used the computer, how much do you think you learned compared with other learning activities?
- \_\_\_\_\_ 1) Learned much more using the computer
  - \_\_\_\_\_ 2) Learned more using the computer
  - \_\_\_\_\_ 3) Learned about the same amount using the computer
  - \_\_\_\_\_ 4) Learned less using the computer
  - \_\_\_\_\_ 5) Learned much less using the computer
6. When you used the computer, how fast do you think you learned compared with other learning activities?
- \_\_\_\_\_ 1) Learned much faster using the computer
  - \_\_\_\_\_ 2) Learned faster using the computer
  - \_\_\_\_\_ 3) Learned in about the same time using the computer
  - \_\_\_\_\_ 4) Learned slower using the computer
  - \_\_\_\_\_ 5) Learned much slower using the computer
7. When you used the computer, how did it affect the use of your time during the annex?
- \_\_\_\_\_ 1) Made much better use of my time -- Wasted much less
  - \_\_\_\_\_ 2) Made better use of my time -- Wasted less
  - \_\_\_\_\_ 3) Made little or no difference in use of my time
  - \_\_\_\_\_ 4) Made worse use of my time -- Wasted more
  - \_\_\_\_\_ 5) Made much worse use of my time -- Wasted much more

8. How interested were you in going through the practice exercises on the computer?
- \_\_\_\_\_ 1) Very interested while using the computer
  - \_\_\_\_\_ 2) Interested while using the computer
  - \_\_\_\_\_ 3) Not interested while using the computer
  - \_\_\_\_\_ 4) Bored while using the computer
  - \_\_\_\_\_ 5) Very bored while using the computer
9. How often did you try to get to the highest difficulty level of the practice exercises?
- \_\_\_\_\_ 1) Almost always tried to get to the highest difficulty level
  - \_\_\_\_\_ 2) Often tried to get to the highest difficulty level
  - \_\_\_\_\_ 3) Sometimes tried to get to the highest difficulty level
  - \_\_\_\_\_ 4) Rarely tried to get to the highest difficulty level
  - \_\_\_\_\_ 5) Never tried to get to the highest difficulty level
10. Would you like to use the computer for other training?
- \_\_\_\_\_ 1) Would very much like to use the computer
  - \_\_\_\_\_ 2) Would like to use the computer
  - \_\_\_\_\_ 3) Undecided
  - \_\_\_\_\_ 4) Would not like to use the computer
  - \_\_\_\_\_ 5) Would very much not like to use the computer
11. How would you advise a friend who had a choice between taking a course where there was a great deal of use of the computer or another course without the computer?
- \_\_\_\_\_ 1) Fight tooth and nail to get into the computer course
  - \_\_\_\_\_ 2) Request the computer course, if convenient
  - \_\_\_\_\_ 3) Neither request nor avoid the computer course
  - \_\_\_\_\_ 4) Avoid the computer course, if possible
  - \_\_\_\_\_ 5) Avoid the computer course like the plague



APPENDIX E

INSTRUCTOR QUESTIONNAIRE  
INSTRUCTOR/STAFF HHC EVALUATION

*Please complete this form to the best of your ability so that the use of the hand-held computer in this course can be fully and fairly evaluated.*

Today's Date: 22 September 1983  
Day Month Year

1. Please check the item which best describes your role in this course.

     1) Regular instructor (Answer all questions.)

  x   2) School staff (Stop after question 4.)

Please specify your position course writer and project NCO

2. What do you feel are the instructional advantages of using the HHC in this course? It is mind against machine which holds the interest of the student.

3. What do you feel are the instructional disadvantages of using the HHC in this course? The programs are too slow.

4. What changes in training practices occurred in this course because of the use of the HHC? No.

5. If the use of the HHC became more widespread (used in more lessons in this course and more courses in the school), how would your role be changed?     

No.

In Questions 6 through 12, compare practice exercises using the HHC with the paper practice exercises. For each question, please check the one box which best describes your opinion about the impact of the use of the HHC in Annex C.

	Greatly Increased	Increased	Little Or No Change	Decreased	Greatly Decreased
How Did Use of the HHC Affect:					
6. Student learning in the annex?		X			
7. Instructor's confidence and feeling of usefulness?		X			
8. Student attention in the annex?		X			
9. Student confidence in number conversions?		X			
10. Student confidence in Boolean algebra?		X			
11. Efficient use of student's time in the annex?		X			
12. Instructor availability to assist students during the annex?		X			

Please check the one response that best describes your opinion.

13. I would like to see the HHC used in other annexes in this course.

- 1) Strongly agree
- 2) Agree
- 3) Undecided
- 4) Disagree
- 5) Strongly disagree

because of the technical aspect of the rest of the course.

14. I would like to see the HHC used in other courses at the school.

- 1) Strongly agree
- 2) Agree
- 3) Undecided
- 4) Disagree
- 5) Strongly disagree

15. How easy or difficult was it for you to obtain student data from the HHC?

- 1) Very easy
- 2) Easy
- 3) Neither easy nor difficult
- 4) Difficult
- 5) Very difficult

16. How useful was the student data you obtained?

- 1) Very useful
- 2) Useful
- 3) Not useful

17. Rate the usefulness of each of the following HHC practice exercises on a scale of 1 (not useful) to 10 (useful):

	<u>Circle One Number</u>									
	<u>Not Useful</u>									<u>Useful</u>
a. Decimal to binary conversion	1	2	3	4	5	6	7	8	9	10
b. Binary to decimal conversion	1	2	3	4	5	6	7	8	9	10
c. Decimal to octal conversion	1	2	3	4	5	6	7	8	9	10
d. Octal to decimal conversion	1	2	3	4	5	6	7	8	9	10
e. Decimal to hexadecimal conversion	1	2	3	4	5	6	7	8	9	10
f. Hexadecimal to decimal conversion	1	2	3	4	5	6	7	8	9	10
g. One digit hexadecimal hangman	1	2	3	4	5	6	7	8	9	10
h. Two digit hexadecimal hangman	1	2	3	4	5	6	7	8	9	10
i. Binary addition	1	2	3	4	5	6	7	8	9	10
j. Binary subtraction	1	2	3	4	5	6	7	8	9	10
k. Boolean logic	1	2	3	4	5	6	7	8	9	10

18. How much assistance did students require to use the HHC?

- 1) A great deal of assistance
- 2) Some assistance
- 3) Little assistance

19. If you had the choice of teaching another course where there was major use of the HHC, would you:

- 1) Fight tooth and nail to be assigned as the instructor
- 2) Request assignment, if convenient
- 3) Neither request nor avoid assignment
- 4) Avoid assignment, if possible
- 5) Avoid assignment like the plague

20. Add any comments, ideas, or stories about the use of the HHC below.

I did not use the instructor program as I could use RCL and # sequences and get the same info much faster. For teaching (remedial or additional), the HHC is good for the students, and the instructor should have more time for the students then.





# COMPUTERS, PERIPHERALS & CALCULATORS

Personal Computation

Users' Library, Custom Services Program

651



## HP Users' Library

The Users' Library is dedicated to making programs contributed by HP-67, HP-97 and HP-41 users available to others. You'll discover a wide variety of programs written for specific applications areas. The solutions you need may already exist! As a subscriber to the Library, you will receive the *Catalog of Contributed Programs* and the *Contributor's Guide*, periodic supplements, and coupons for four programs of your choice complete with pre-recorded magnetic cards. You will also receive the *HP Key Notes* newsletter, which keeps you abreast of programming techniques, Library activities, and notes of interest.

Ordering Information	Price
First Year Subscription	\$20.00
Annual Renewal	\$10.00
HP-67, HP-97 Programs (Includes program descriptions/listings, and magnetic cards.)	\$6.00
HP-41C, HP-41CV Programs (Includes program descriptions/listings, magnetic cards, and bar code.)	\$6.00

## Custom Services

HP Custom Services satisfies the growing need for specialization in portable computing products. Through customization, the powerful HP-41C and HP-41CV calculators can be tailored to do your dedicated complex or repetitious calculations when and where you need them.

Using customer or third party written programs, the HP-41 or an HP-41 with blank keys (Option 001), can be customized using one of three options: custom ROM's, custom magnetic cards or custom bar code. Each option is designed to suit particular information and problem-solving requirements. When selecting one of these alternatives, consideration is given to: frequency of code alterations, desired program capacity, updating of variables in your data, required level of privacy and initial investment. For assistance, consult your local HP Field Engineer.

## HP 82500A or 8 Custom Modules (ROM's)

4K or 8K bytes of memory with each module. Nearly 21,000 program lines with up to four 8K modules.

## HP 82502A Custom Magnetic Cards

Used with the HP-41C, HP-41CV, HP-67, and HP-97. Each card can be customized to load 175 to 200 instructions.

## Custom Bar Code

Inexpensive way to load custom programs or data. Available from an independent vendor.

The HP-41 saves time, lowers cost, and ensures accuracy for both the technical and non-technical user. The standard HP-41 allows you to retain access to the full programmable capabilities and scientific functions of the calculator even after it has been customized.

A custom HP-41C or HP-41CV Option 001 with a blank keyboard, is made as friendly as possible. This special calculator limits use to those keys you have designated, minimizing potential user error. Custom overlays, (HP 82501A), label keys for either calculator and provide the final, professional touch.

Already many companies have improved their productivity with customized HP-41's. Proven applications, from banking to fuel savings, from media buying to heavy equipment sales and service, from circuit design to diamond sales, give the same result, increased performance and improved productivity.

## Ordering Information

Quantity	Custom Modules		Custom Mag Card 4K (18 cards/set)	Custom Bar Code 4K (6 cards/prog) (3 prog)
	8K	4K		
100	NA	NA	\$99 / set	\$3 51 / set
250	\$102	\$ 63	\$46 / set	\$3 02 / set
500	\$ 52	\$ 39	\$28 / set	\$2 86 / set
1000	\$ 42	\$ 27	\$19 / set	\$2 78 / set
5000	\$ 26	\$ 17	\$12 / set	\$2 72 / set



# COMPUTERS, PERIPHERALS & CALCULATORS

HP-41 Peripherals, Software, Accessories

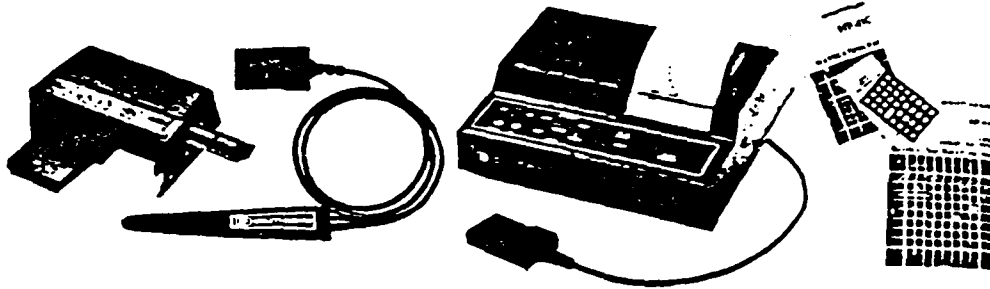

### HP 82104A Card Reader

Reads and writes programs and data onto magnetic cards with 32 registers per card. Adds over 30 card reader control functions to your calculator, including prompt and program security. Also reads HP-67/97 program cards.

### HP 82143A Thermal Printer/Plotter

Portable, quiet, thermal operation, and battery operable, the HP 82143A prints upper- and lower-case alpha characters, including special characters you can create. The Printer/Plotter also does high-resolution plotting routines.

### HP 82153A Optical Wand

Inputs data by reading programs in the form of bar code. Most HP-41 software is available in bar code, including Users' Library programs and solutions books.

### HP-41 Application Pacs

Whether you're an engineer or technician, student or scientist, business person or other professional, you'll find an application pac or solutions book to solve many of the most common and difficult problems in your area.

Every application pac comes with a comprehensive manual, and, when applicable, a keyboard overlay. Choose from:

- Aviation
- Clinical Lab & Nuclear Medicine
- Circuit Analysis
- Financial Decisions
- Mathematics
- Games
- Home Management
- Real Estate
- Thermal & Transport Science
- Petroleum Fluids
- Securities
- Statistics
- Stress Analysis—Mechanical Engineers
- Structural Analysis—Civil Engineers
- Surveying
- Machine Design
- Navigation

### HP-41 Solutions Books

#### Business:

- Business Statistics/Marketing/Sales
- Home Construction Estimating
- Lending, Savings, & Leasing
- Real Estate
- Small Business

#### Engineering:

- Antennas
- Chemical Engineering
- Civil Engineering
- Control Systems
- Electrical Engineering

- Fluid Dynamics & Hydraulics
- Heating, Ventilating, & Air Conditioning
- Mechanical Engineering
- Solar Engineering

#### Computation:

- Geometry
- High-Level Math

- Test Statistics

#### Other:

- Calendars
- Cardiac/Pulmonary
- Chemistry
- Games
- Optometry I (General)

- Optometry II (Contact Lenses)
- Physics
- Surveying
- Taxes

### Ordering Information

Ordering Information	Price
HP-41C	\$250.00
HP-41CV	\$325.00
HP 82106A Memory Module	\$30.00
HP 82170A Quad Memory Module	\$95.00
HP 82104A Card Reader	\$215.00
HP 82143A Thermal Printer/Plotter	\$385.00
HP 82153A Optical Wand	\$125.00
HP-41 Application Pacs	\$30.00 to \$75.00
HP-41 Solutions Books	\$12.50

### Calculator Accessories

A Hewlett-Packard calculator purchase is a smart decision. Power, convenience, and quality from a company you can depend on. But HP calculators also have a versatility unequalled in the industry. There's a complete accessory line engineered to provide the support you need. No matter what type of Hewlett-Packard calculator you choose, you'll find it supported by a full line of replacement accessories and supplies to keep it operational.

